

QUANTUM

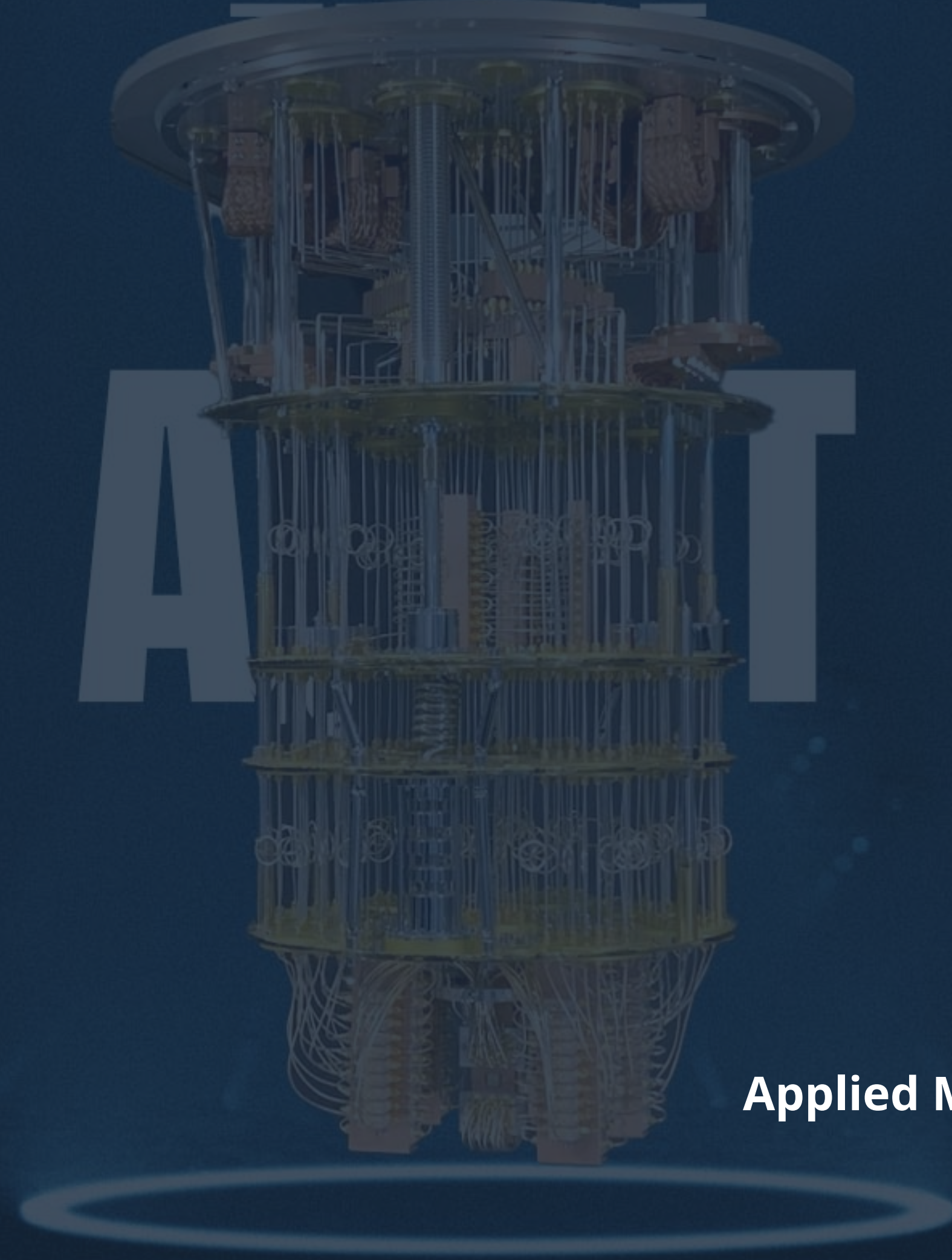

TA: Yousra Farhani
Applied Machine Learning Course, NBI

$\langle \phi_k | \phi_{k'} \rangle = \langle \phi_k | \int_{-l/2}^{+l/2} dx |x\rangle \langle x| \phi_{k'} \rangle \Rightarrow \left(\frac{2\pi}{l}n + k_0\right) \frac{l}{2} = \frac{\pi}{2}(2l-1), l=1,2,\dots \Rightarrow k_0 = -\frac{\pi}{l}$

$\langle \phi_k | \phi_{k'} \rangle = \int_{-l/2}^{+l/2} dx \phi_k^*(x) \cdot \phi_{k'}(x) \quad \psi_n(x) = \sqrt{\frac{2}{l}} \cos\left[\frac{\pi}{l}(2n-1)x\right]; \psi_a - \psi_b = \pi; \psi_n(x) = \sqrt{\frac{2}{l}} \sin\left[\frac{2\pi}{l}nx\right]$

$\langle \phi_k | \phi_{k'} \rangle = \frac{1}{l} \int_{-l/2}^{+l/2} dx e^{-ikx} e^{ik'x} \stackrel{!}{=} 0; k \neq k'$

$\hat{H} \psi_{ns}(x) = -\frac{\hbar^2}{2m} \partial_x^2 \psi_{ns}(x) = \frac{\hbar^2}{2m} \left(\frac{\pi}{l}[2n-1]\right)^2 \psi_{ns}(x)$
 $E_{ns} = \frac{\hbar^2}{2m} \frac{\pi^2}{l^2} (2n-1)^2, n=1,2,\dots; \hat{H} \psi_{na}(x) = \frac{\hbar^2}{2m} \left(\frac{2\pi}{l}\right)^2 \psi_{na}(x)$

$|\psi(x)|^2 = |\psi_0|^2 e^{-\frac{(x-x_0)^2}{2a^2}}$
 $\int_{-\infty}^{+\infty} dx e^{-Ax^2} = \sqrt{\frac{\pi}{A}}$
 $A = \frac{1}{2a^2} \Rightarrow |\psi_0| = \frac{1}{(2\pi a^2)^{1/4}}$

$a \approx 10^{-10} \text{ m}$
 $\hat{H} \psi_a = -\frac{\hbar^2}{2m} \partial_x^2 \psi_a(x) = \frac{\hbar^2}{2m} \frac{1}{2a^2} \psi_a(x) - \frac{\hbar^2}{2m} \frac{1}{4a^4} (x-x_0)^2 \psi_a(x)$
 $= -\frac{\hbar^2}{2m} \left(-\frac{1}{2a^2} + \left(\frac{1}{2a^2}(x-x_0)\right)^2\right) e^{-\frac{(x-x_0)^2}{4a^2}} \psi; V(x) = \frac{\hbar^2}{2m} \frac{1}{4a^4} (x-x_0)^2$
 $\hat{H} \rightarrow \hat{H} = -\frac{\hbar^2}{2m} \partial_x^2 + V(x); \hat{H} \psi_a = \frac{\hbar^2}{2m} \frac{1}{2a^2} \psi_a = E_0 \psi_a$
 $V(x) = \frac{1}{2} m \omega^2 (x-x_0)^2 \rightarrow m \omega^2 = \frac{\hbar^2}{m^4 a^4} \Rightarrow \omega = \frac{\hbar}{2ma}$
 $E_0 = \frac{\hbar^2}{2m} \frac{1}{2a^2}$

$[\hat{p}, \hat{x}] = \frac{\hbar}{i}; \hat{p} = \frac{\hbar}{i} \partial_x / \hat{H} = \frac{\hat{p}^2}{2m} + \frac{1}{2} m \omega^2 \hat{x}^2$
 1. $a^2 + b^2 = (a+ib)(a-ib); a, b \in \mathbb{R}; 2. (a\hat{p} + ib\hat{x})(a\hat{p} - ib\hat{x}), a, b \in \mathbb{R}$
 $= a^2 \hat{p}^2 + iba \hat{x} \hat{p} - iab \hat{p} \hat{x} + b^2 \hat{x}^2 = a^2 \hat{p}^2 + b^2 \hat{x}^2 - \text{batu}$
 $\hat{H} = (a\hat{p} + ib\hat{x})(a\hat{p} - ib\hat{x}) = \text{batu}; a^2 = \frac{1}{2m}; b^2 = \frac{1}{2} m \omega^2$
 Def: $C^+ = \frac{1}{\sqrt{\hbar\omega}} (a\hat{p} + ib\hat{x}); C^- = \frac{1}{\sqrt{\hbar\omega}} (a\hat{p} - ib\hat{x}) \Rightarrow \hat{H} = \hbar\omega C^+ C^- + \frac{1}{2} \hbar\omega$
 $\left\{ \left(\frac{2\pi}{\omega} - \frac{\epsilon}{\omega}\right) | \omega, \epsilon \in \mathbb{C} \right\} \left\{ \frac{\pm 1}{2} \right\} iSU(2) \cong S^3 \quad A \rightarrow \omega \bar{A} \omega^{-1}$

$\langle (x-x_0)^k \rangle = \langle \psi_0 | (x-x_0)^k | \psi_0 \rangle = \int_{-\infty}^{+\infty} dx \psi_0^*(x) (x-x_0)^k \psi_0(x)$

$\int_{-\infty}^{+\infty} dx \psi_n^*(x) (x-x_0)^k \psi_a(x) = \langle \psi_n | (x-x_0)^k | \psi_a \rangle$



The Quantum Debate - Equally Valid

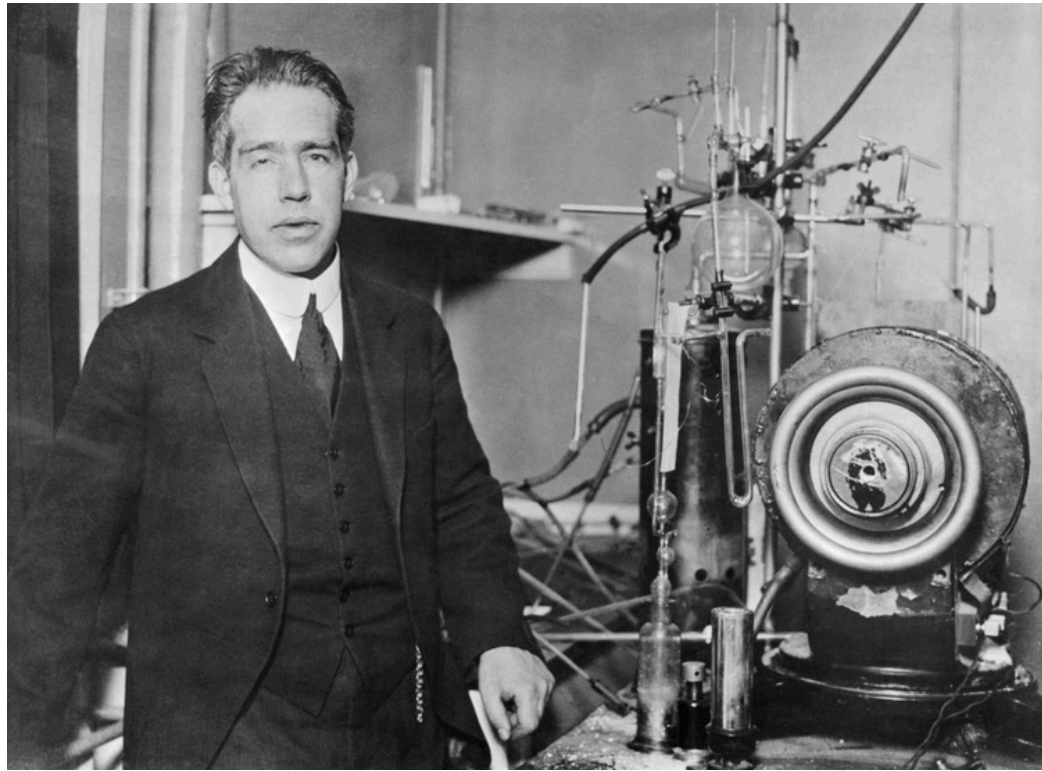

Niels Bohr - The Copenhagen Interpretation

Quantum mechanics is complete

“Reality or the state of the particle at a fundamental level does not have definite properties until it is measured”

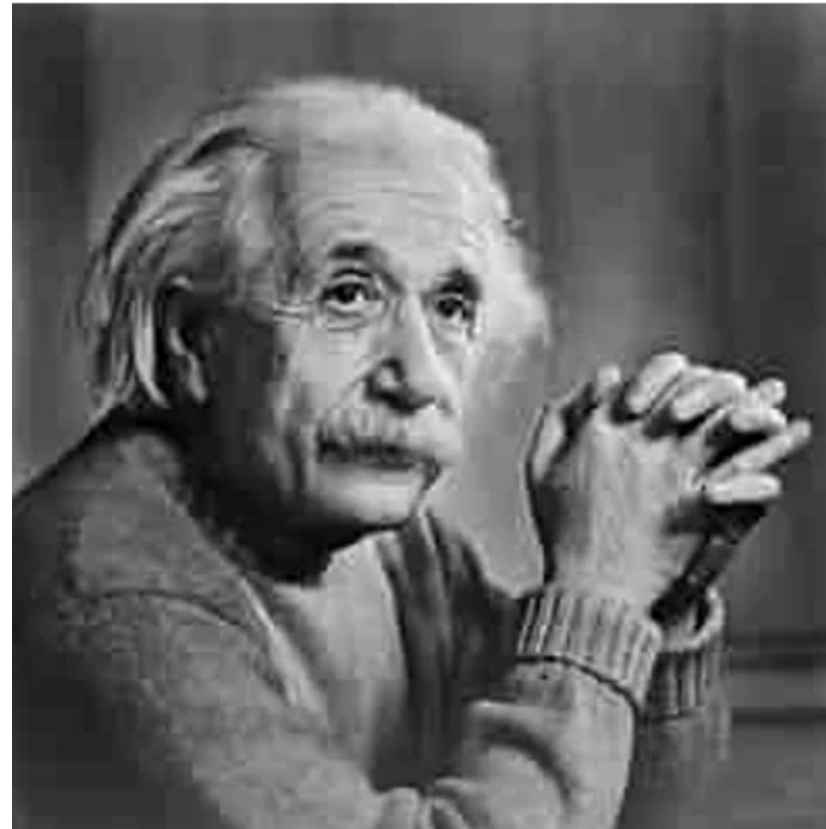

Albert Einstein (Realism)

Quantum mechanics is incomplete

“Reality is knowable, Physics should describe an objective reality that exists independently of observation”

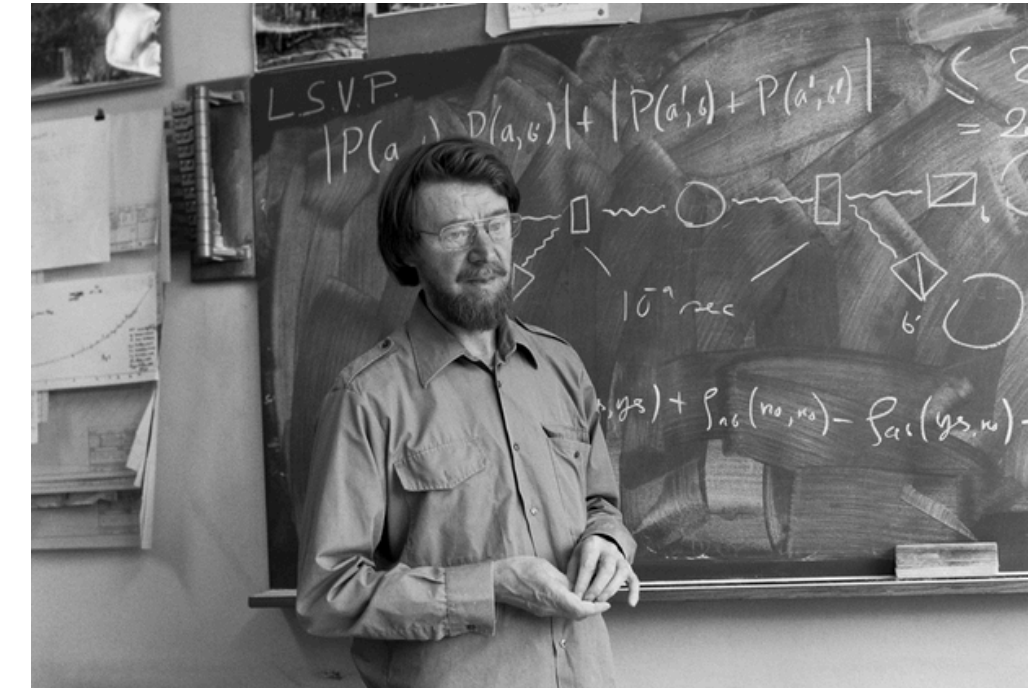

John Bell - Closing the Gap



EPR PARADOX

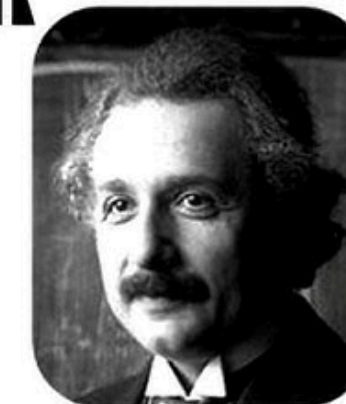

A. Einstein



B. Podolsky



N. Rosen

Einstein-Podolsky-Rosen paradox



Flip the coin Game



ROBERT



JOHN





**Flip the coin
Game**



Normal Computer

**0101
1001
0110**

Bits



HEAD

0.5

**Probability of
50% to win**



TAIL

0.5



**What if they played this game
on a Quantum Computer?**

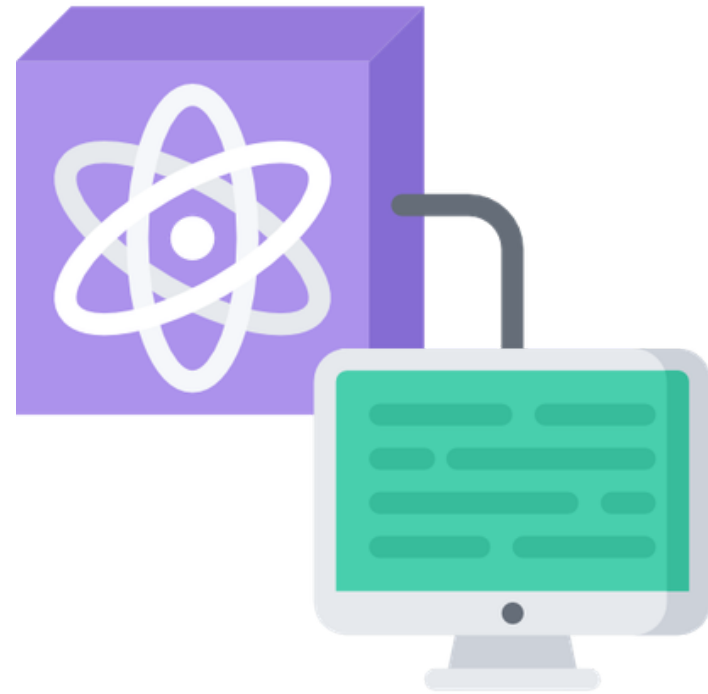

Quantum Computer

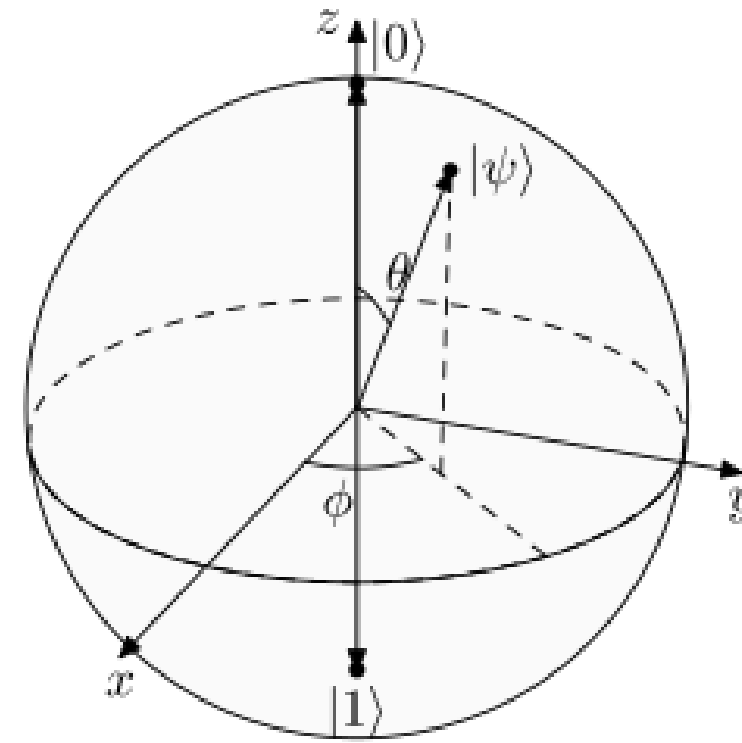

Qubit



HEAD



TAIL

Both

probability to Lose > Win



Quantum Computational Advantage



**As many bits as the number of atoms
in the visible universe !!!!!!!!!!!!!!!!**

**Classical Computer Can never
simulate reality**

**Simulate and Translate the
correlations of few hundred particles**

Too way complexe!!

Not feasible!!!

Complexity Theory Framework

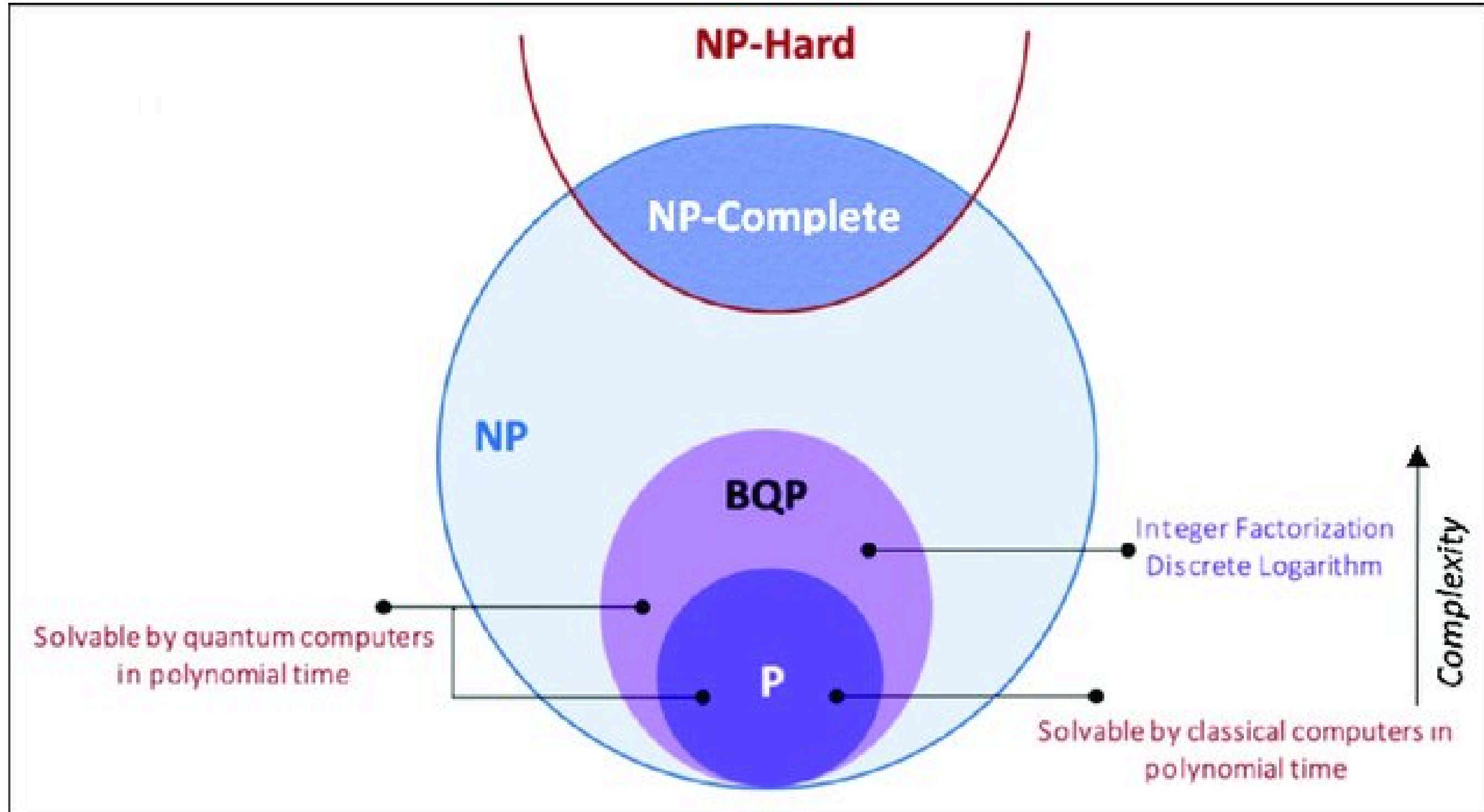

Theoretical computer scientists have demonstrated that quantum computers can efficiently solve problems within the BQP (Bounded-Error Quantum Polynomial Time) complexity class.



Gordon Moore

Moore's Law

The number of transistors on a microchip
doubles every two years.

1965

3 nm or less



BUT...

Moore's Law reached a limit!

Compute Cost

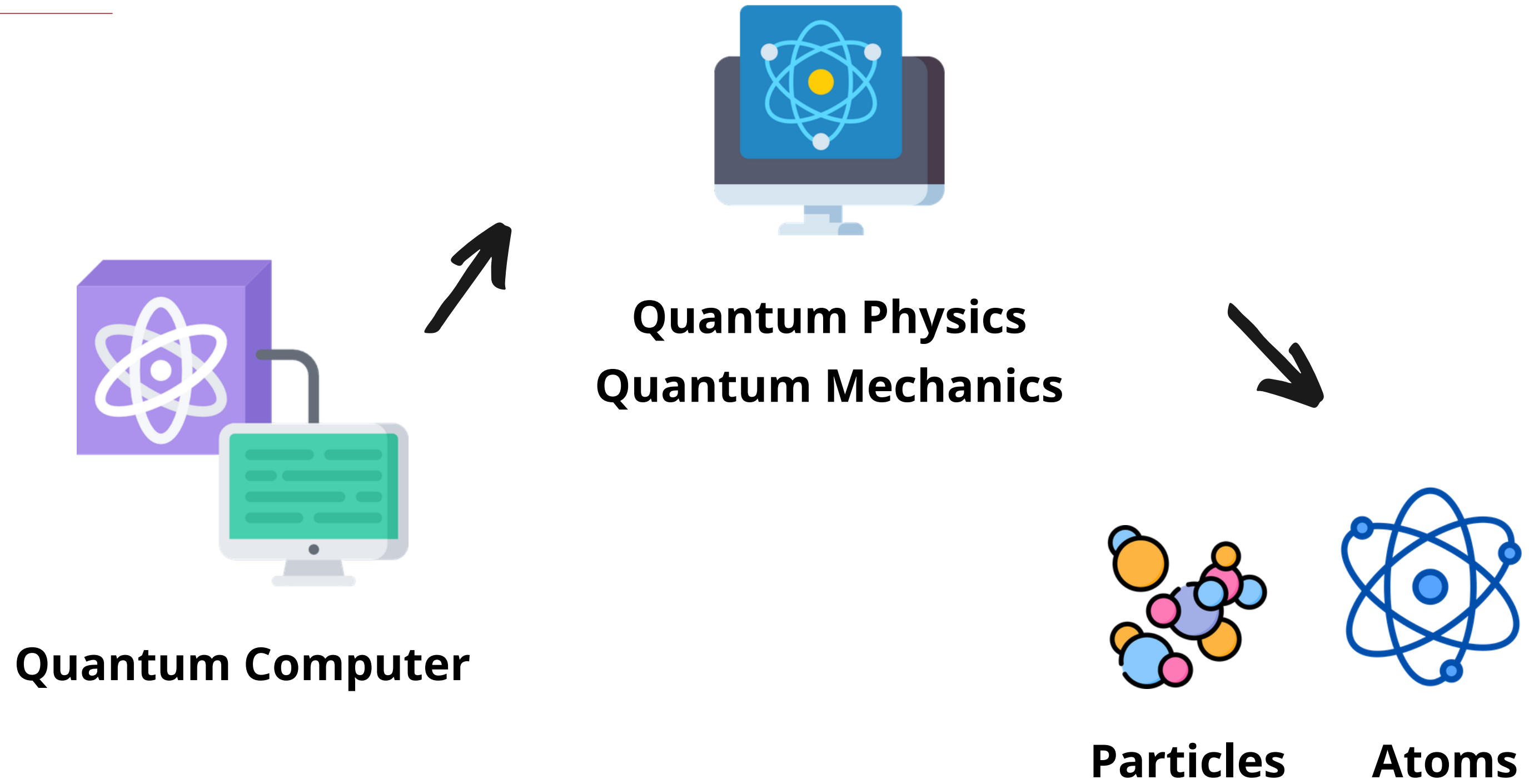



Quantum Superposition

The characteristic of a quantum superposition is that particles exists in multiple distinct quantum states at the same time

Quantum Machine

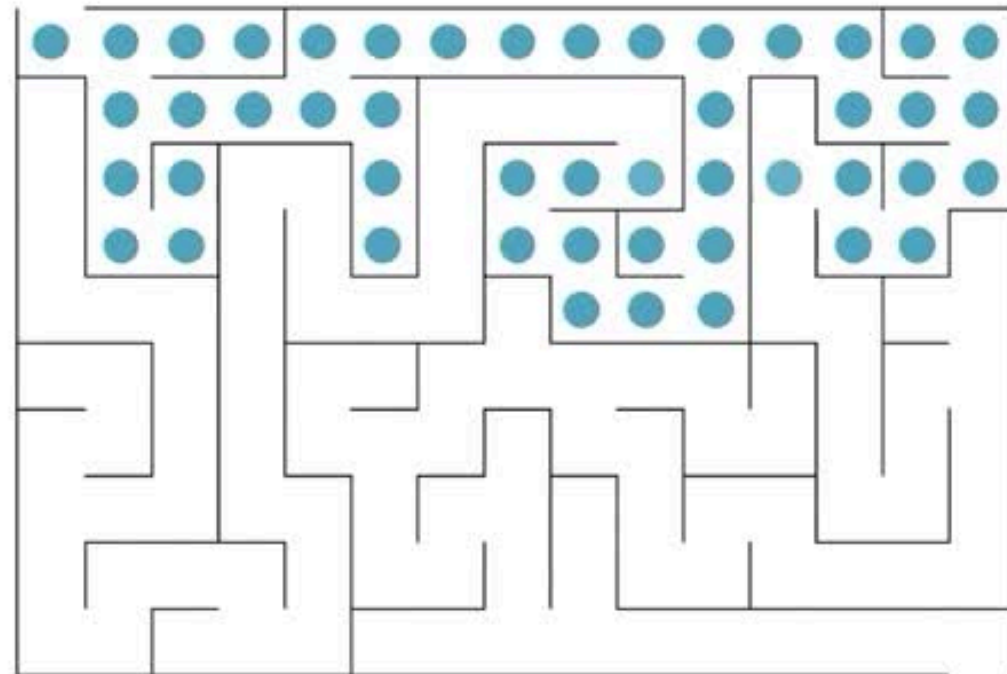

Classical Machine

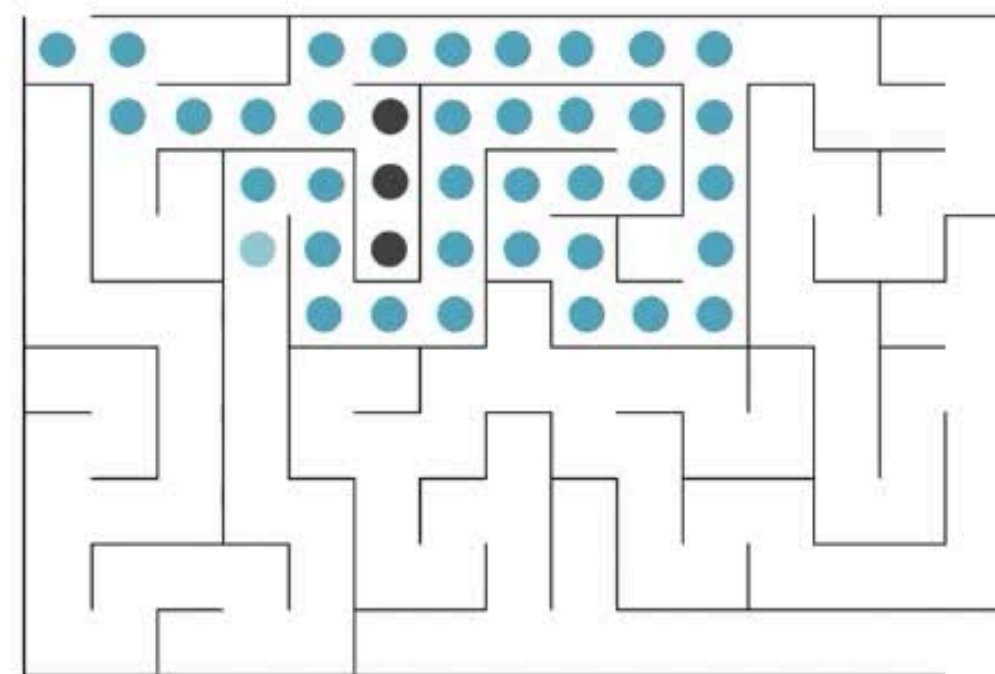

Quantum Superposition

Quantum Uncertainty & Measurement

Quantum uncertainty is the idea that, when you look at tiny things like atoms and particles, you can't always know everything about them at the same time.



SCHRÖDINGER'S CAT

$$|\text{cat}\rangle = \alpha \left| \text{cat sitting} \right\rangle + \beta \left| \text{cat dead} \right\rangle$$



Quantum Entanglement

Two particles are bound together, no matter how far apart they are

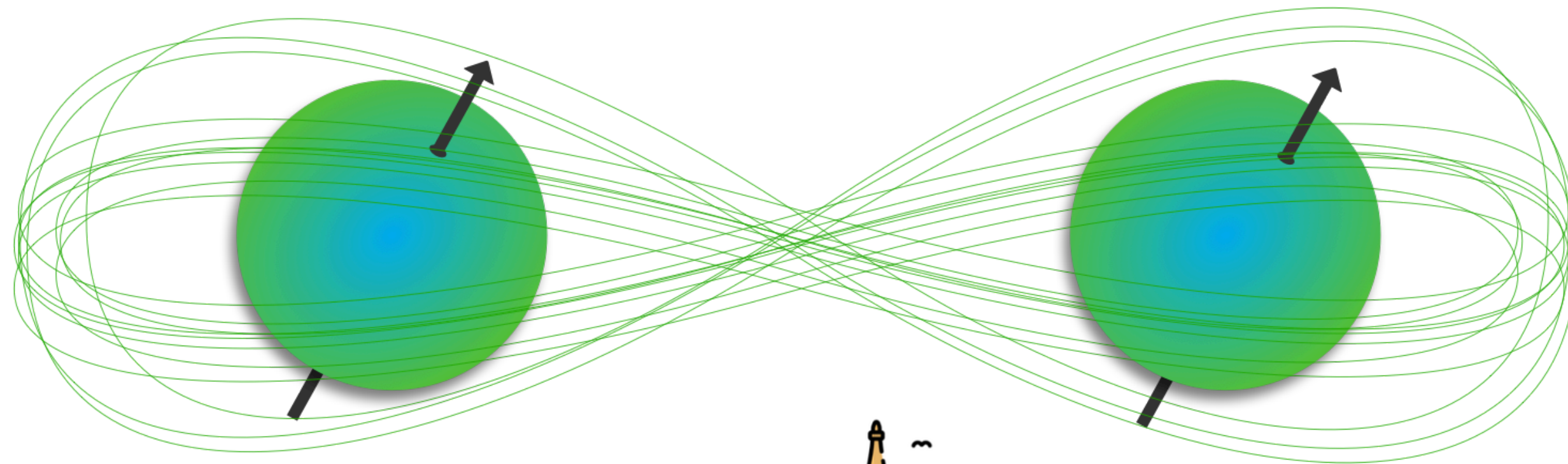

Paris



NYC



What is a Qubit?

Classical Computing

1

0

Bits are stored either as a
0 or 1

Quantum Computing

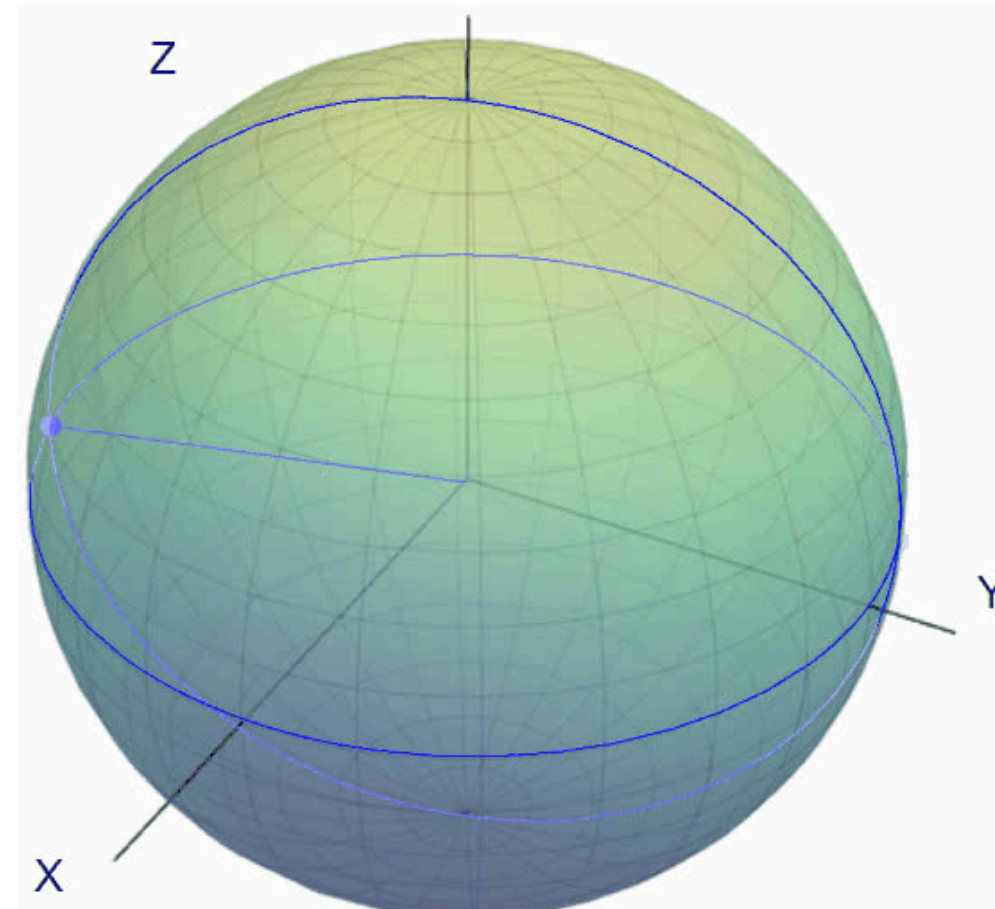

Superposition

Qubits can be stored anywhere
between 0 and 1



Qubits Representation

$$| \Phi \rangle \langle \Psi |$$

Bra-Ket Dirac Notation

A mathematical framework using
Kets to represent the state we're in
Bras to represent the state we're
going to or measuring.

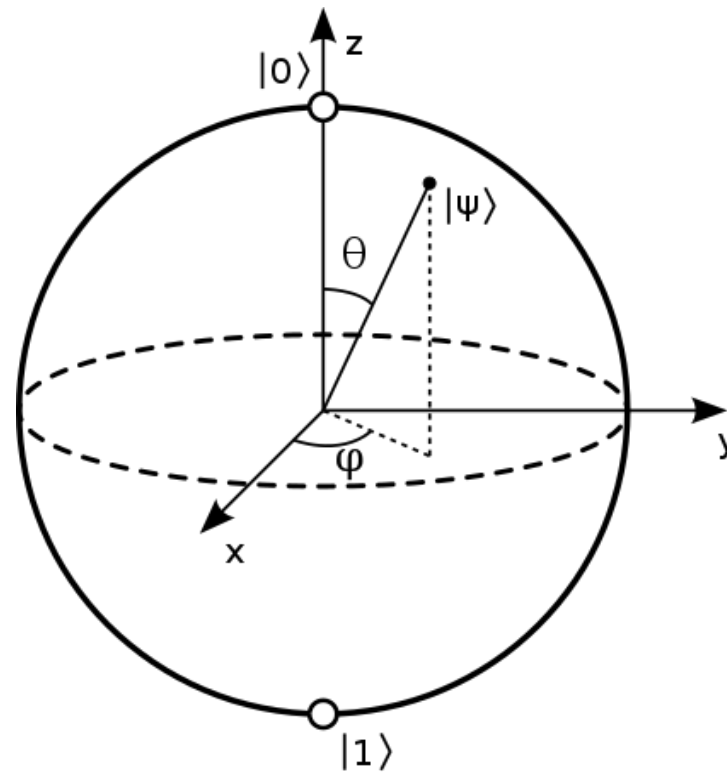

Bloch Sphere

$$|1\rangle = \begin{bmatrix} 0 \\ 1 \end{bmatrix}$$

Vector

$$|\psi\rangle = \alpha|0\rangle + \beta|1\rangle$$

Quantum gates

Superposition

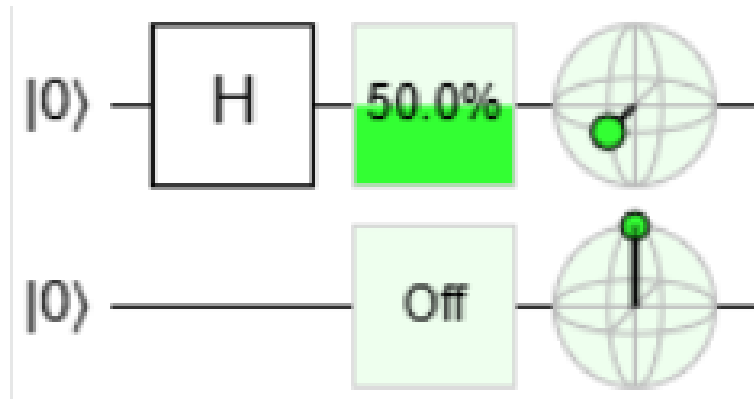

Qubit flip

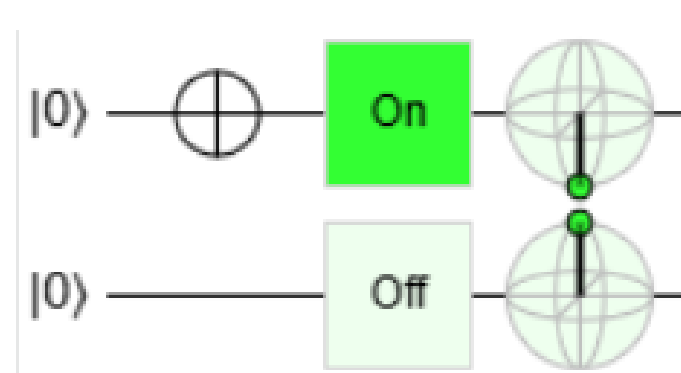

Rotation gate

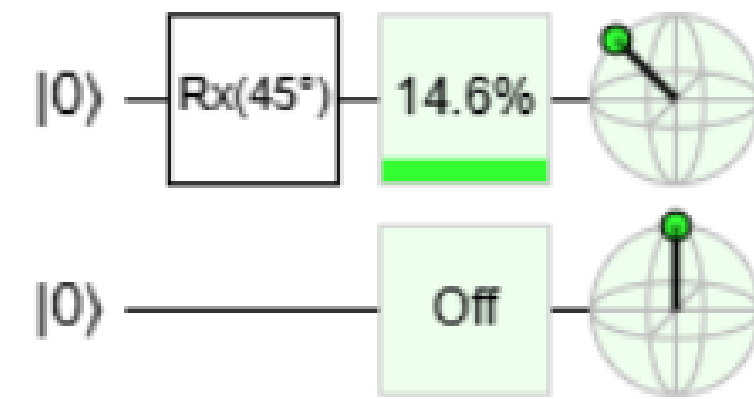

Entanglement

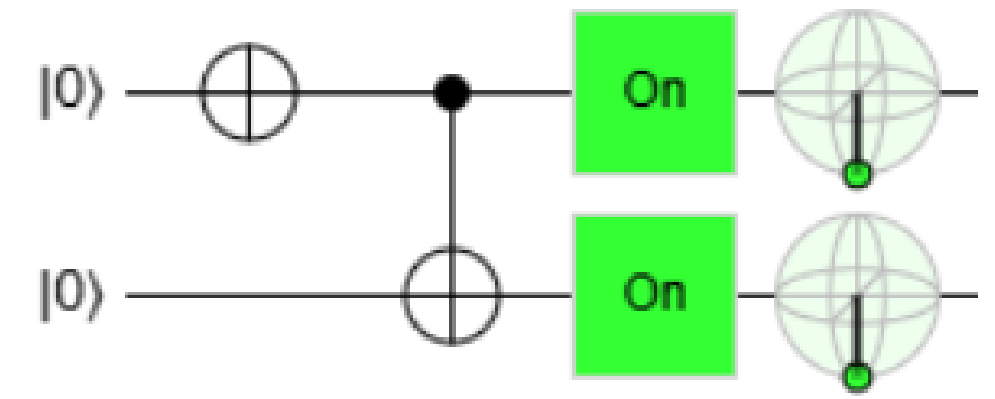

Bell state (Perfectly correlated qubits)

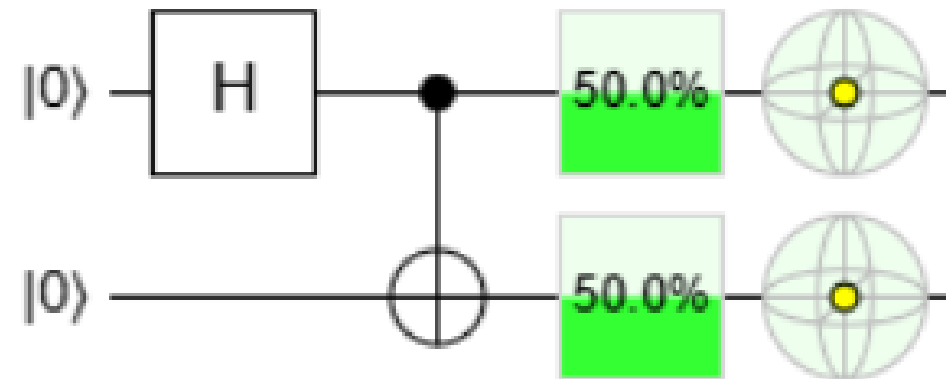

SWAP gate (SWAP $|a, b\rangle = |b, a\rangle$)

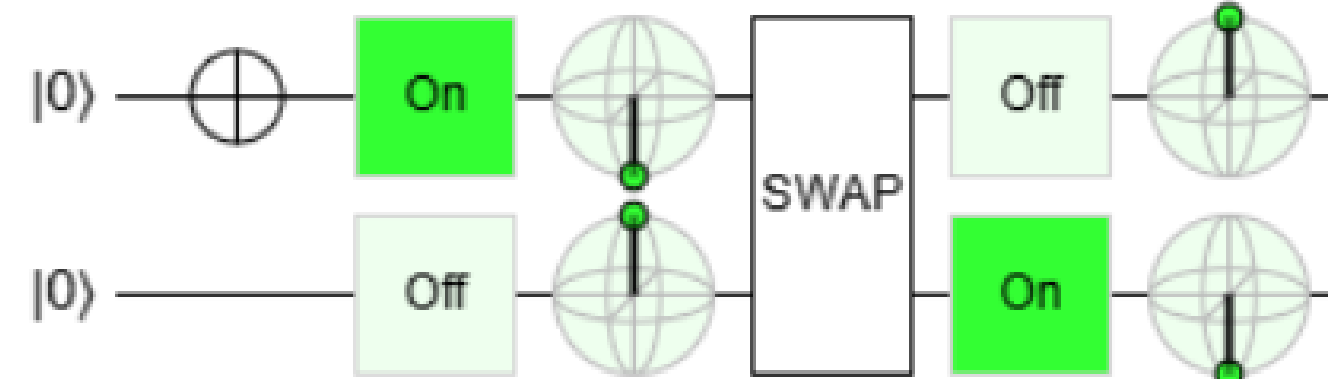

IS IT JUST ME

**OR THAT DOESN'T MAKE ANY
SENSE**



If you think you understand
quantum mechanics, you don't
understand quantum mechanics.

— *Richard P. Feynman* —





Types of Quantum Computers (Modalities)

**Superconducting Circuit
Based Computer
(Artificial Atoms)**

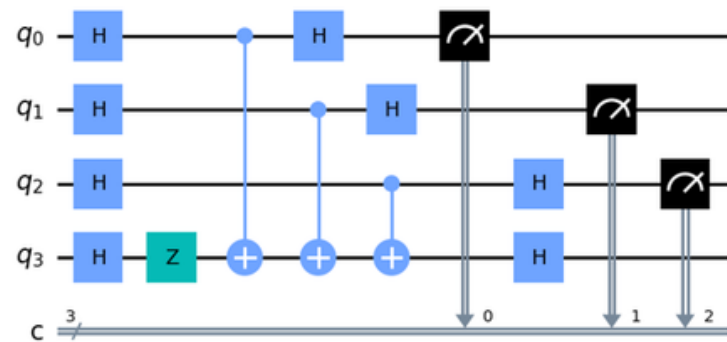

**Trapped Ions
(Charged Atoms)**

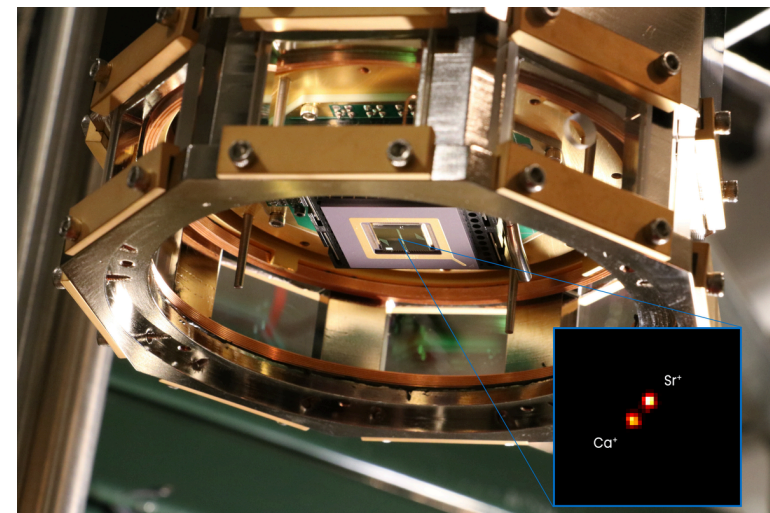
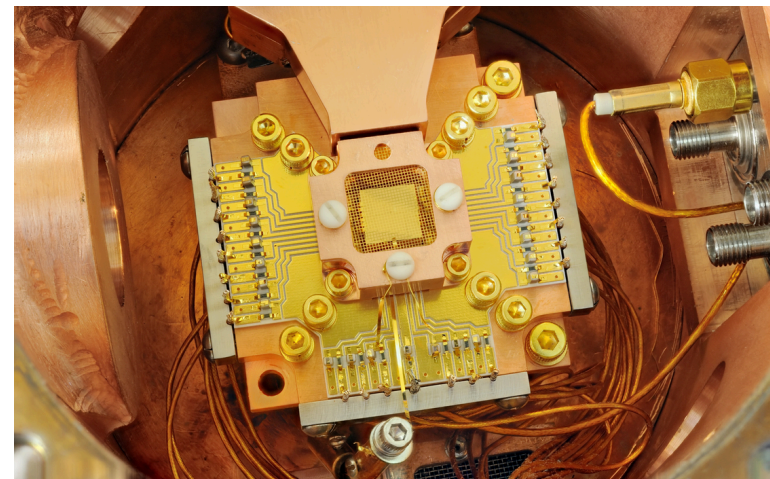

**Photonic Quantum
Computer
(Light Particles)**

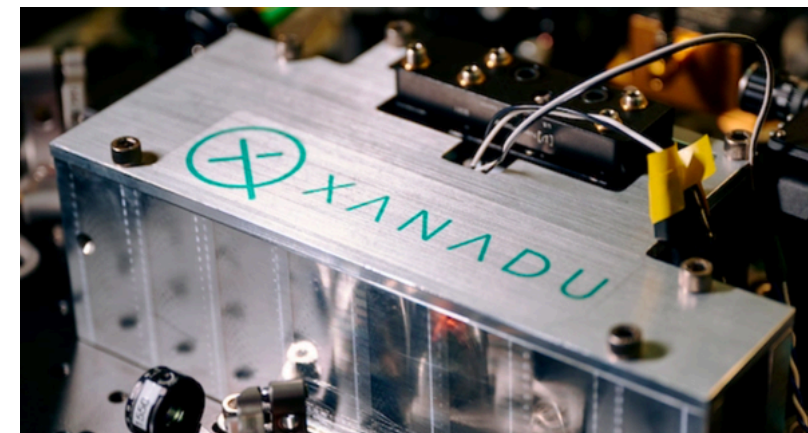
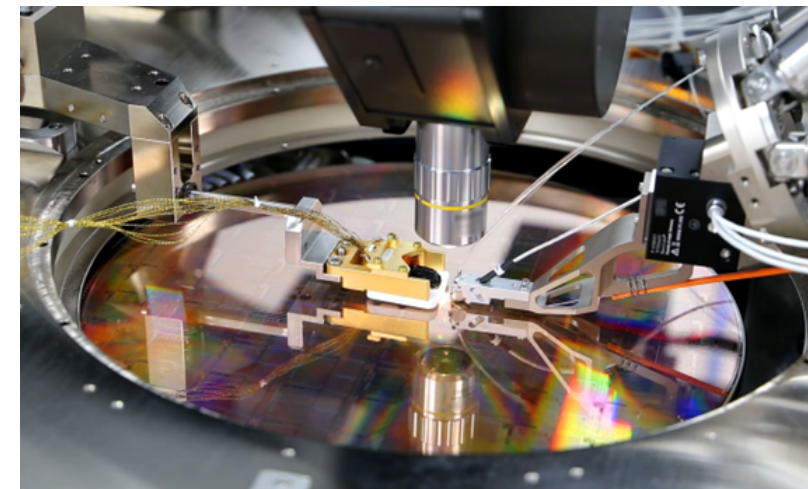

**Quantum Annealers
(Coupled Qubits)**





KØBENHAVNS
UNIVERSITET

Caltech Quantum Computer



Caltech

The largest qubit array ever assembled
6,100 neutral-atom qubits trapped in a
grid by lasers

Superposition for about 13 seconds

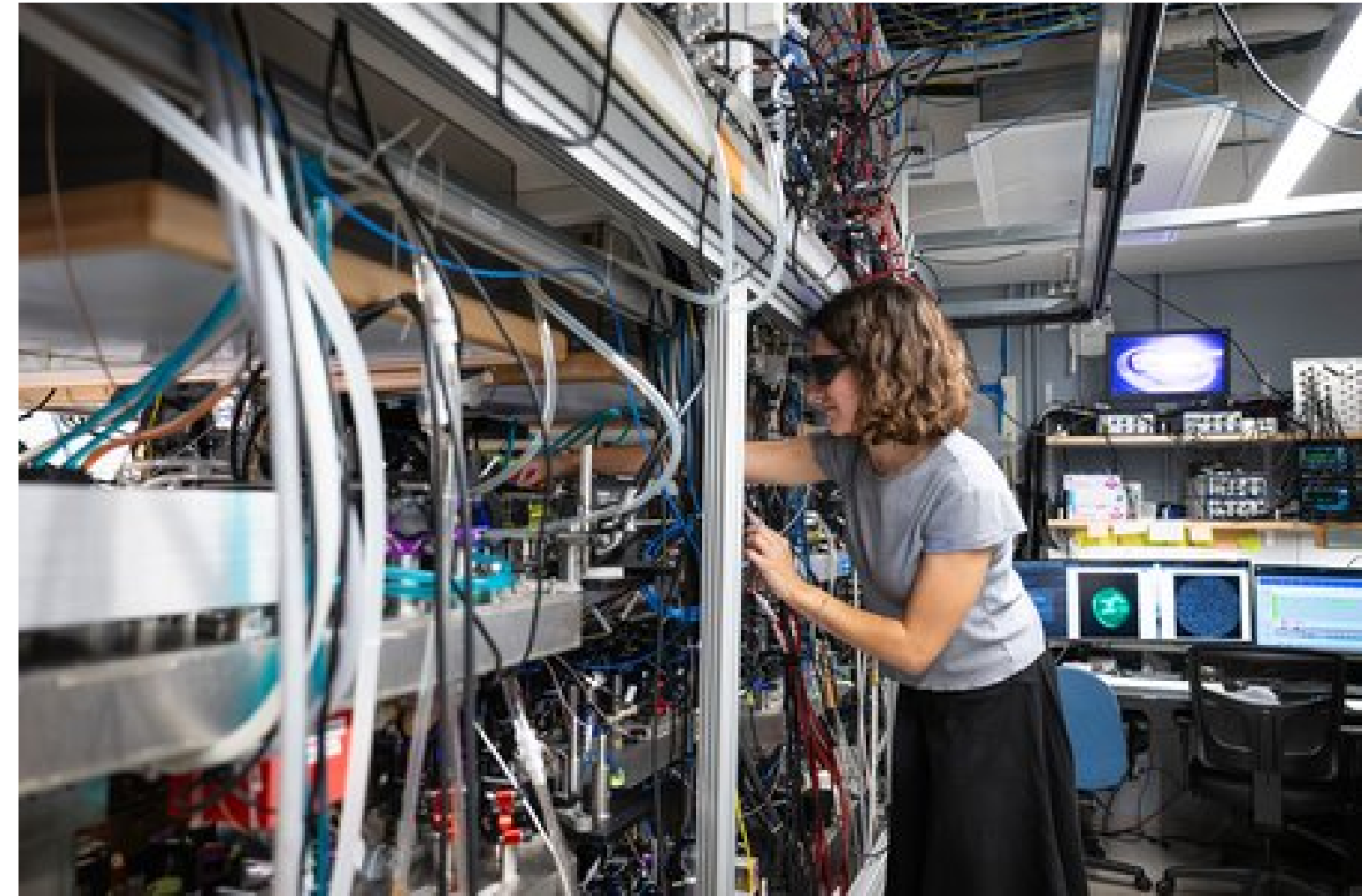



Magne Quantum Computer - Neutral Atoms

 **atom
computing** **QuNorth[®]**

 **Microsoft**

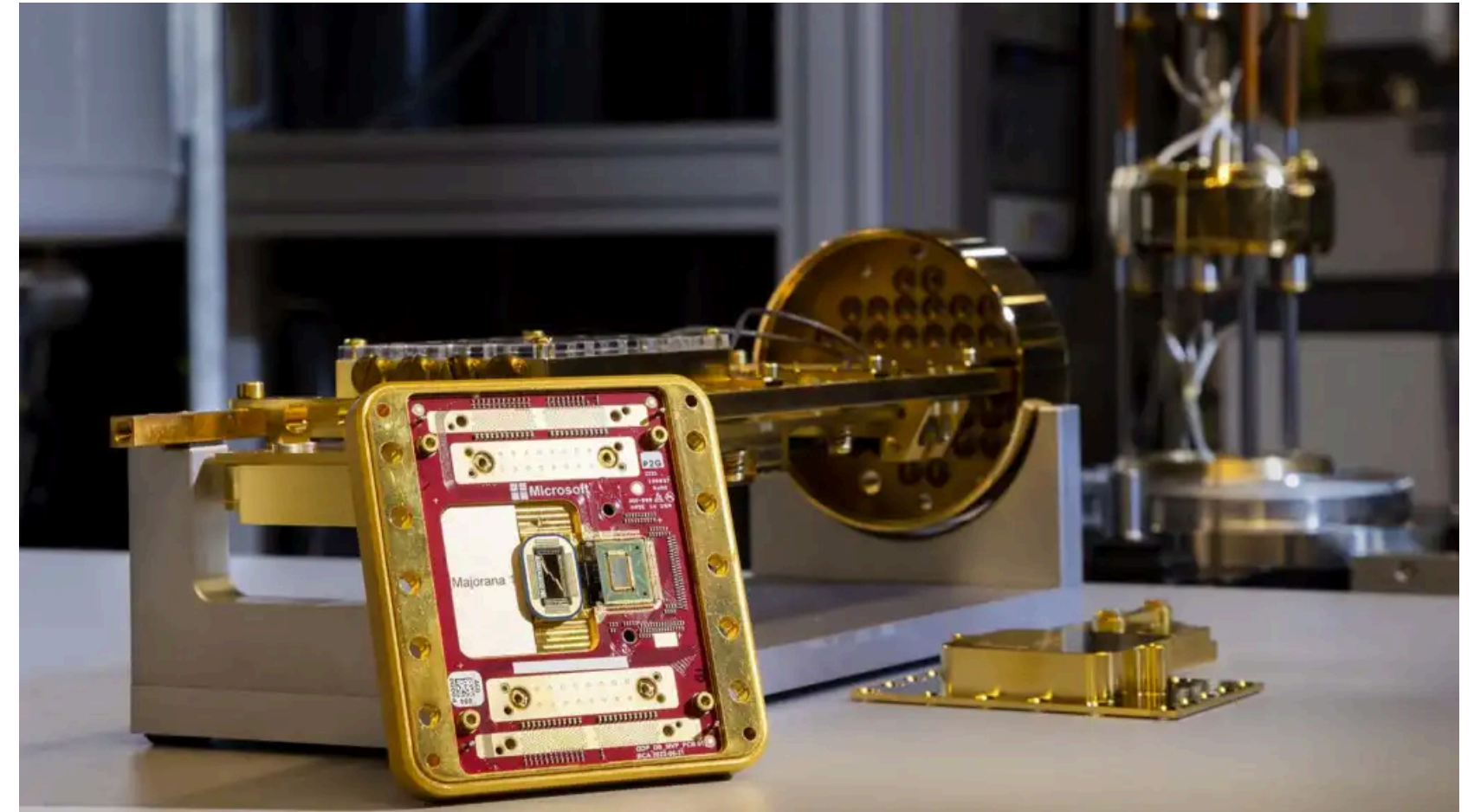

**One of the Largest Quantum Computer with 50
logical qubit**

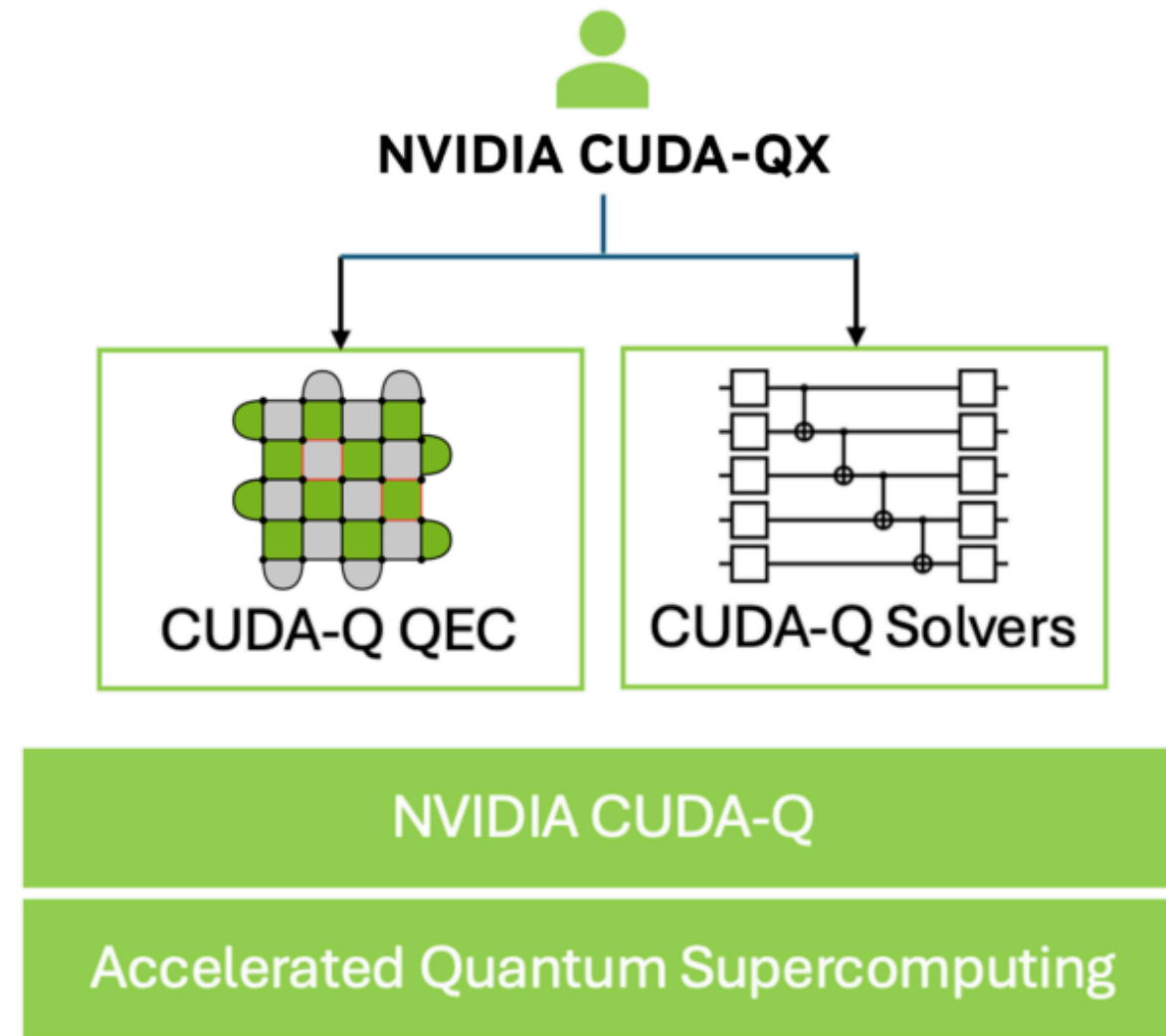

NVIDIA Accelerated Quantum Computing Research Center (NVAQC)

14 Collaborator including Quantinuum, QuEra, Quantum Machines, Pasqal, and researchers from MIT and Harvard



IBM Quantum Data Center
Ehningen, DE



Industrial Use Cases

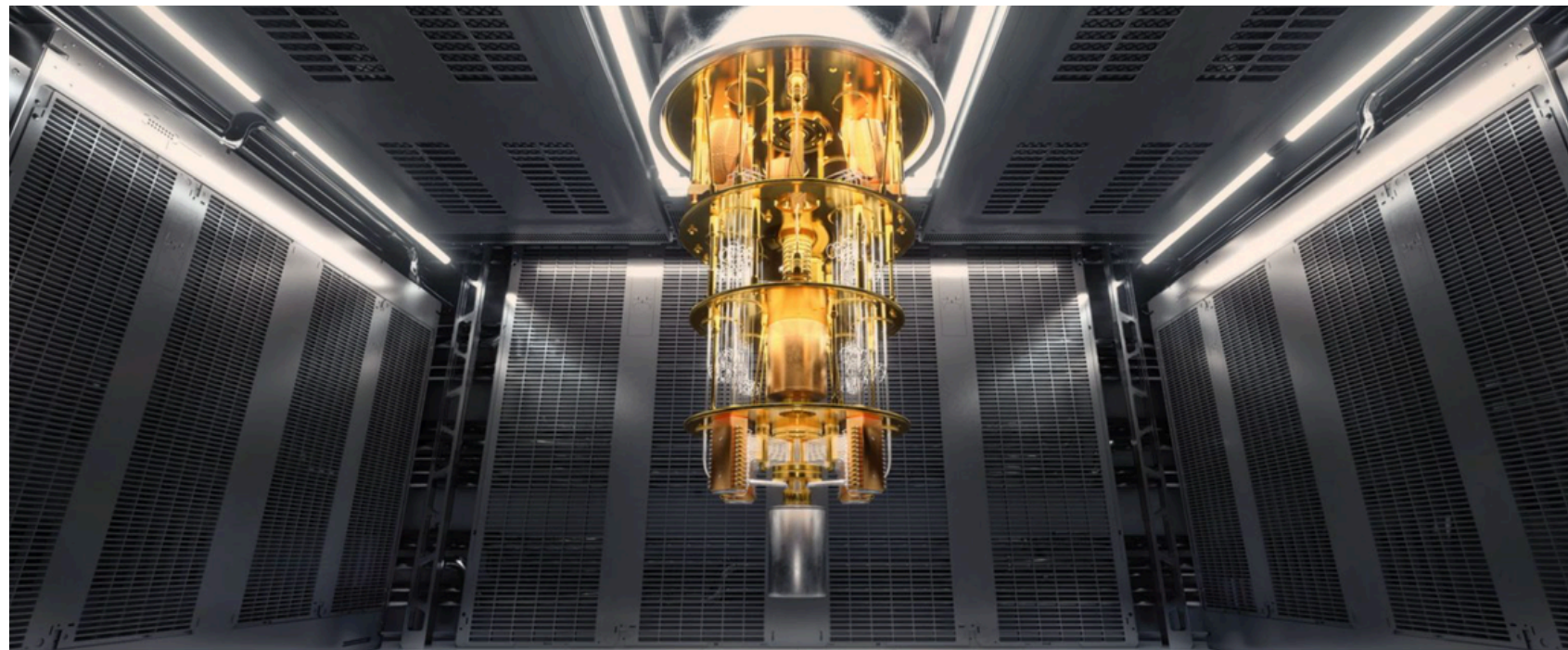

[← Back](#)



INNOVATION | 04.02.2025 | ⌚ 4 Min.

QUANTUM COMPUTING AT THE BMW GROUP.

Blog

February 21, 2024

iMessage with PQ3: The new state of the art in quantum-secure messaging at scale

Posted by Apple Security Engineering and Architecture (SEAR)





The Rapid Evolution of Quantum Hardware (2023–2025)

IBM Quantum

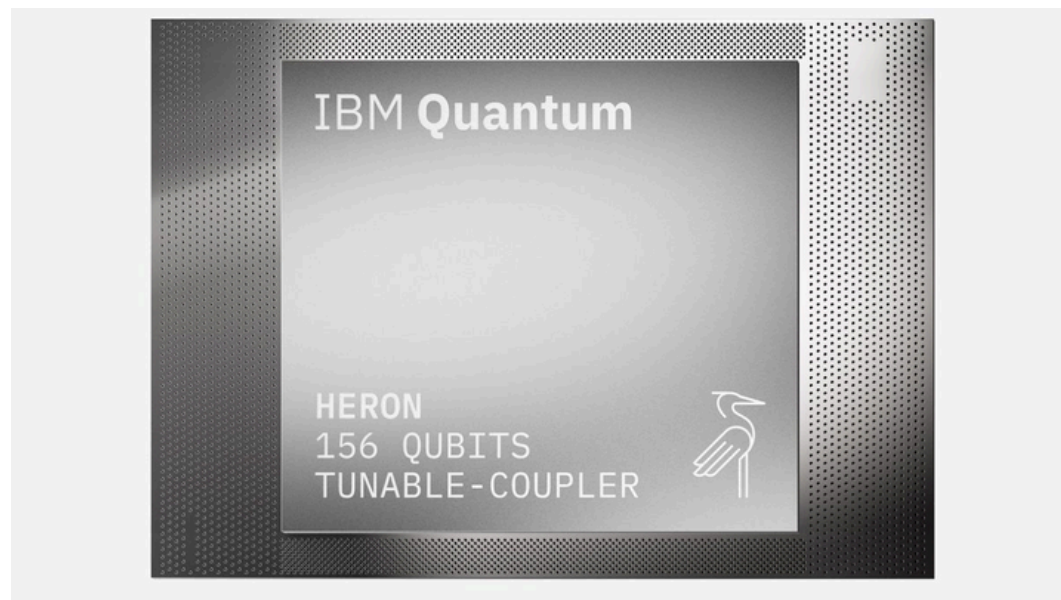

**Heron is a 156-qubit tunable-coupler quantum processor
Fault-tolerant by 2029**

- ✓ 3× lower gate errors than previous devices
- ✓ Modular architecture optimized for scaling

Google Quantum AI

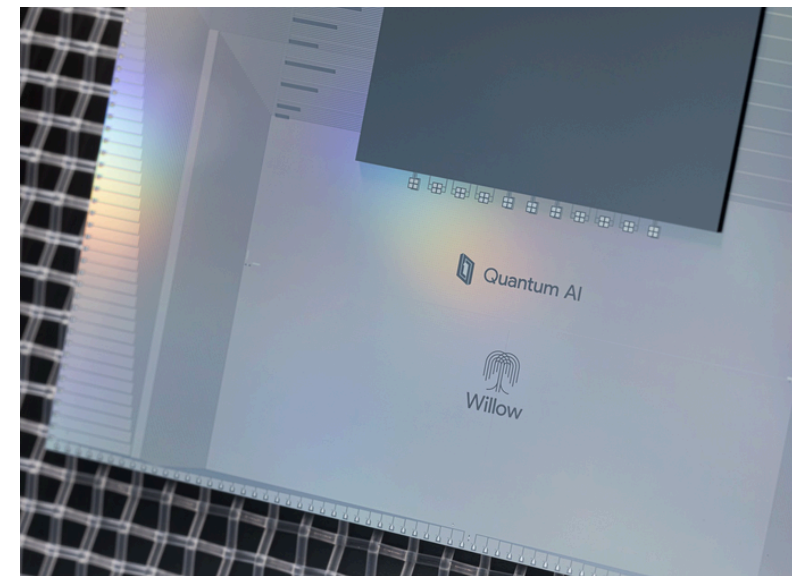

**Willow 105-qubit superconducting “transmon” processor unveiled in
December 2024**

- ✓ Exponentially decreasing error rates as the qubit lattice scales
- ✓ the first time a superconducting chip has reached “below-threshold” error correction

D-Wave Annealer

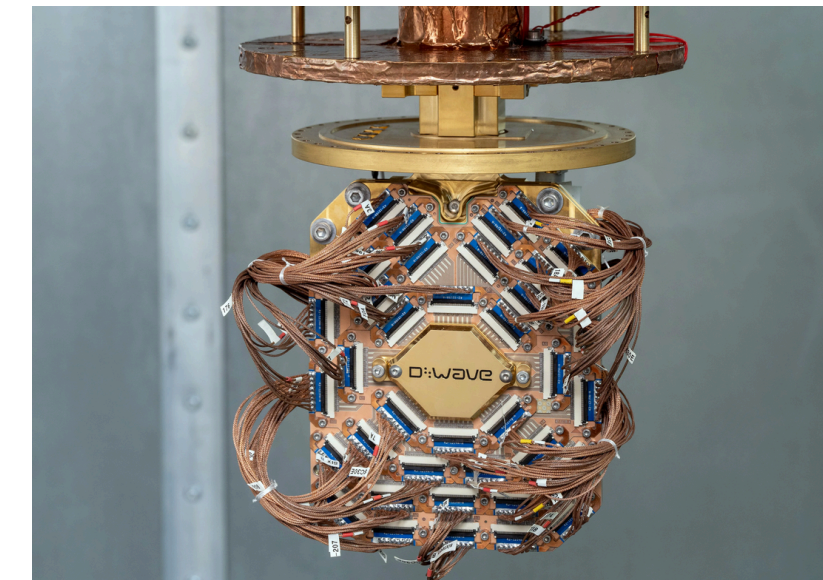

With 5000+ qubits and advanced connectivity using Pegasus / Zephyr topologies

- ✓ Have been used for several industrial use cases
- ✓ D-Wave’s Advantage2 outperformed the Frontier supercomputer on a materials simulation task involving spin glasses, 2025



Explosive Growth in Quantum Algorithms Research (2024–2025)

MNIST Fashion Classification Using Quantum Convolutional Neural Networks

Nasir Ali
Embedded Systems Division
Centre for Development of Advanced Computing
Noida, India
nasirali2607@gmail.com

Abhishek Tiwari
Embedded Systems Division
Centre for Development of Advanced Computing
Noida, India
abhishek@cdac.in

Rahul Kumar Neiwai
Electronics Division
Ministry of Electronics and Information Technology
New Delhi, India
rahul.neiwai@meit.gov.in

Abstract—This paper explores the innovative application of Quantum Convolutional Neural Networks (QCNN) in the classification of the MNIST fashion dataset. Quantum computing presents novel opportunities for enhancing machine learning algorithms, particularly in handling complex datasets. The MNIST fashion dataset is a large collection of Zalando's article images, serves as an ideal candidate for demonstrating the efficacy of QCNN. This paper dives into the implementation of QCNN, compares QCNN's performance with traditional neural networks, and further evaluates QCNN's potential in revolutionizing image classification tasks in the realm of Quantum Machine Learning.

Index Terms—Quantum Convolutional Neural Networks, MNIST Fashion Dataset, Quantum Machine Learning

I. INTRODUCTION

Nature is not classical, Nature is Quantum and it follows the laws of Quantum Mechanics at the atomic scale. All classical information we can account for is in terms of classical bits i.e. zeros and ones, which can be either 0 or 1 at a particular time. This classical information can be represented by an electric current signal or some voltage as 1 and zero voltage as 0. Classical bits interact through logic gates like NOT, AND, OR, etc. Similarly, Quantum Information can be represented in terms of Qubits, counterintuitive to our classical notion of information, a Qubit can be 0 or 1 simultaneously. A Qubit being in 0 and 1 state simultaneously is called a superposition state, which can be represented on a Bloch sphere as shown in Fig. 1.

As Moore's law predicted, the number of transistors on a microchip would double approximately every two years, which will lead to exponential growth in computational power [1]. But as the transistors shrink to sizes of a few nanometers, further scaling might be difficult and this is where Quantum Computing comes into the picture. At extremely small scales, electrons can tunnel through insulating barriers due to quantum effects, a process called Quantum Tunneling,

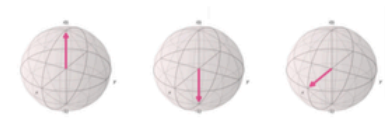

Fig. 1. Qubit $|0\rangle$, Qubit $|1\rangle$ and a superposition state $|+\rangle$ on a Bloch sphere.

which might lead to increased leakage currents and reduced reliability of transistors. Quantum Computing is the answer to these difficulties. Of course, as of now the problems that can be solved using Quantum Computers are very limited but we have to be optimistic to explore Quantum aspects of Classical Algorithms.

In this research, we will explore Quantum Convolutional Neural Networks with the help of Quantum Machine Learning, [2] techniques to classify grayscale images. The MNIST fashion dataset, an extension of the original MNIST dataset, comprises 70,000 grayscale images of fashion items categorized into ten classes. This dataset is widely used in machine learning for classification algorithms due to its moderate complexity and substantial size [3].

Quantum Convolutional Neural Networks (QCNN), an amalgamation of quantum computing and neural network principles, offer a promising approach to handling such datasets [4] [5]. Quantum computing utilizes the principles of quantum mechanics to process information, which can significantly enhance the computational efficiency and capabilities of machine learning models [2] [6]. QCNN, in particular, are designed to exploit quantum mechanical phenomena such as superposition and entanglement to perform convolutions and other neural network operations at

where improvements are needed to realize its full potential.

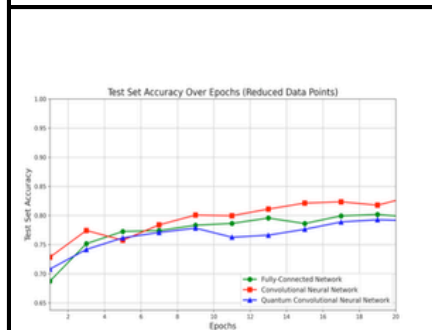

Fig. 6. Performance Comparison (Reduced Data Points).

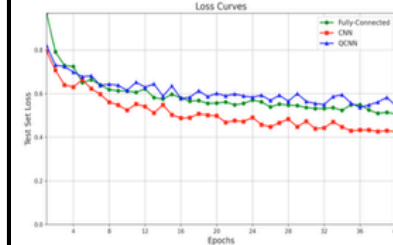

Fig. 7. Training and Validation Curves.

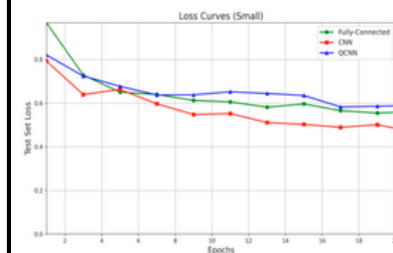

Fig. 8. Training and Validation Curves (Reduced Data Points).

Around **6,647** Published paper on Quantum Machine Learning in ArXiv (2024 - 2025)

Around **35–40%** of QML ArXiv preprints from 2024 were later published in peer-reviewed journals or conference proceedings (e.g., PRX Quantum, Nature Quantum Information, QIP, NeurIPS, ICLR).



QUANTINUUM



ETH zürich

D:wave
The Quantum Computing Company™



“AI will be used to design the next-generation quantum technology, and incorporated into programming, controlling, and error correcting quantum computers.”

— Bert de Jong, Director, Quantum Systems Accelerator (QSA), Senior Scientist, Berkeley Lab.

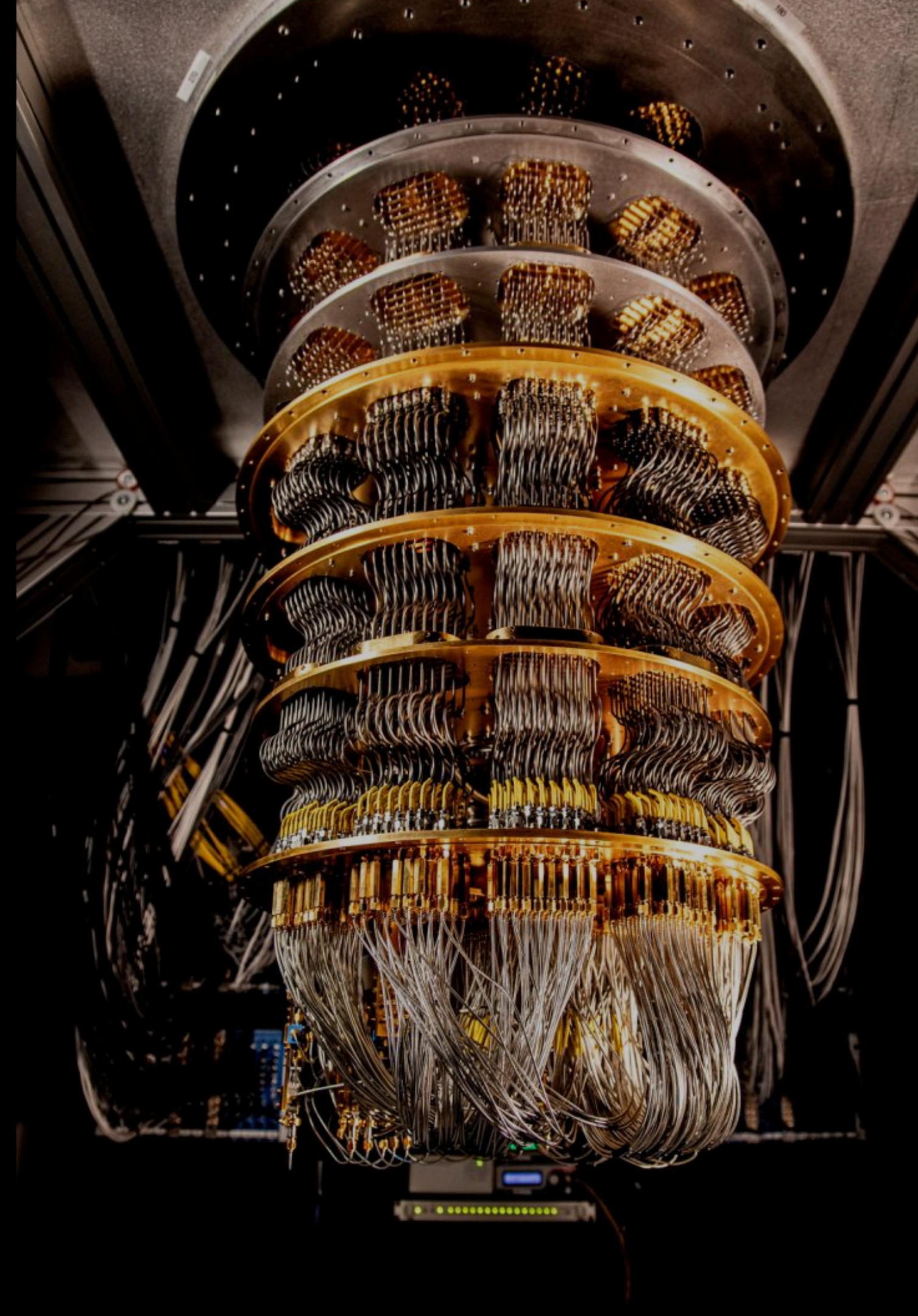



Challenges in Classical Machine Learning

The neural scaling law (kaplan2020scaling) which posits that “bigger is often better”

Since 2020, this principle has driven the development of increasingly colossal models, featuring more complex architectures and an ever-growing number of parameters.



This progress comes at an immense cost

Training a model like ChatGPT on a single GPU
would take approximately **355 years**

The cloud computing costs for training such large models
can reach tens of thousands of dollars





What is Quantum Machine Learning (QML)?

Quantum Machine Learning is the study of algorithms that run on quantum computers and are designed to learn patterns from data leveraging quantum phenomena like superposition, entanglement, and interference to gain computational advantage.

Biamonte, J., Wittek, P., Pancotti, N., Rebentrost, P., Wiebe, N., & Lloyd, S. (2017). Quantum machine learning. Nature, 549(7671), 195-202.

Quantum Machine Learning is a discipline seeking to take advantage of quantum mechanical processes to induce or enhance machine learning (ML). QML combines in novel ways the concepts and algorithms adopted from the Quantum Computing and Machine Learning research, and is underpinned by the formalism of Quantum Mechanics.

Introduction to Quantum Machine Learning Managing high complexity with the volume of data
Jacob L. Cybulski Enquanted, Melbourne, Australia

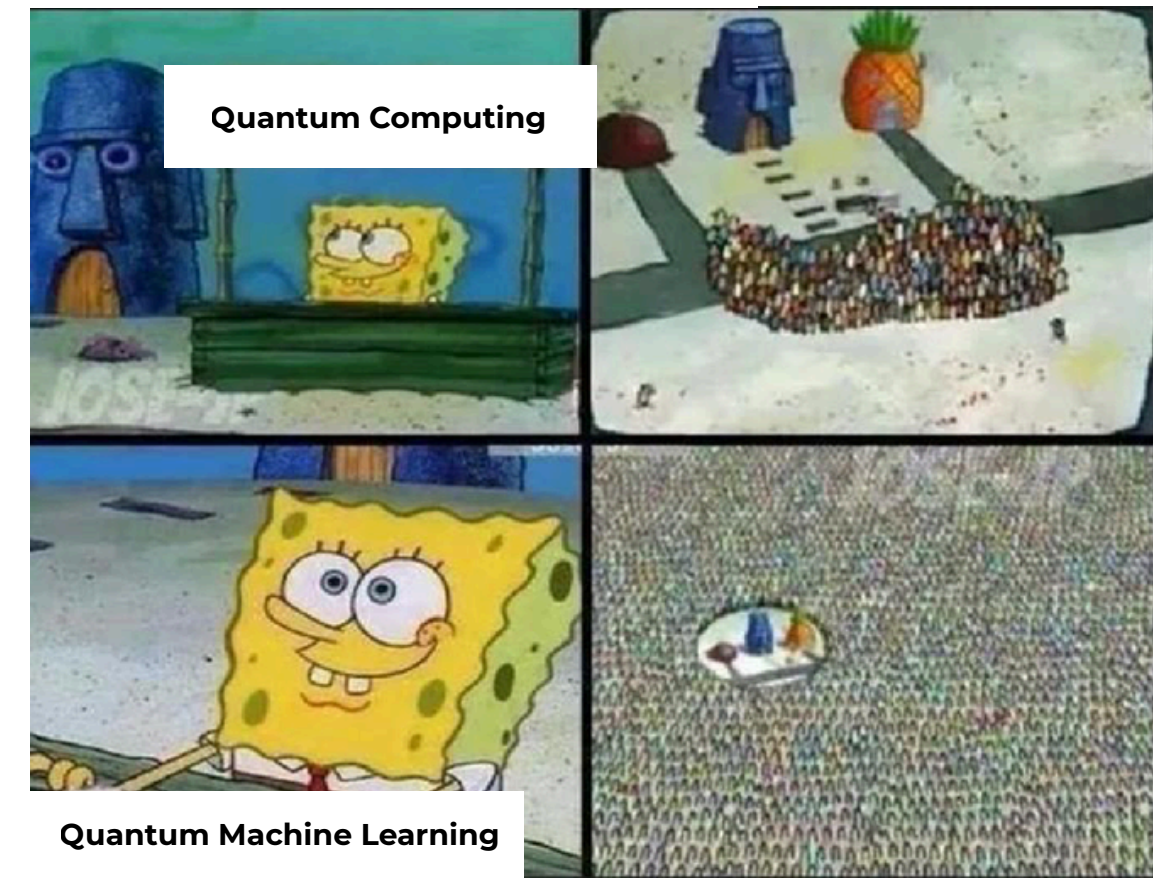
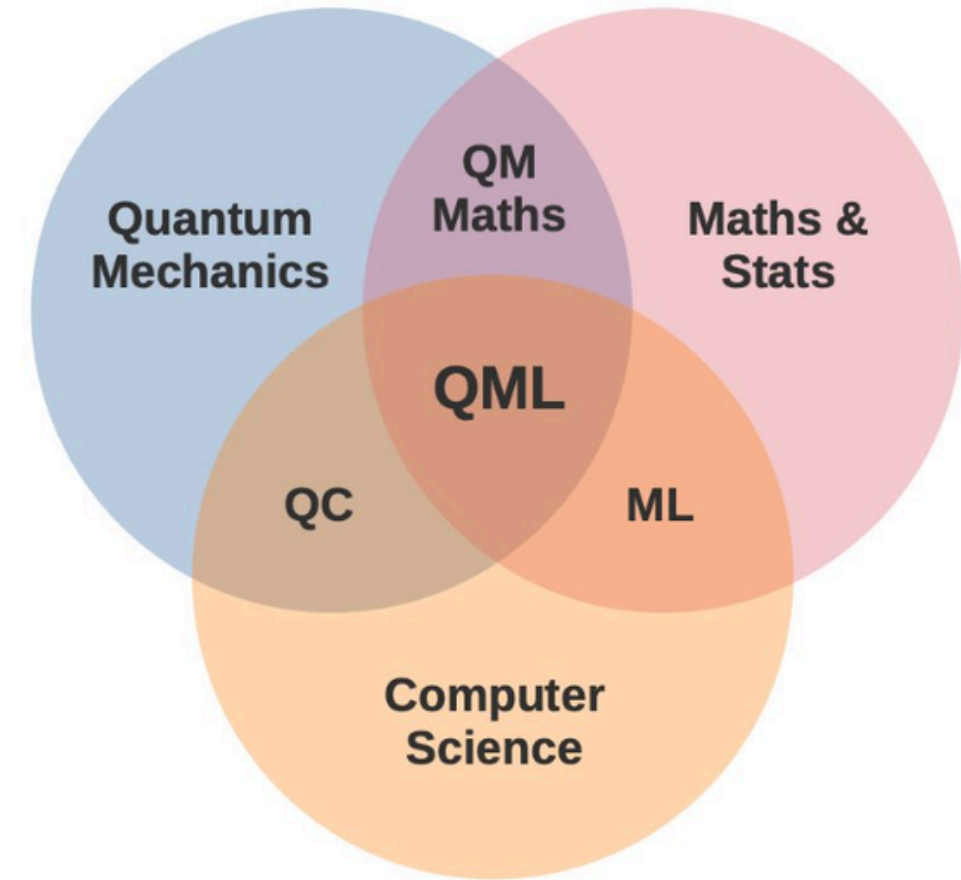



Types of QML Approaches

Quantum-enhanced ML (using quantum systems to improve ML)

- Variational Quantum Classifiers (VQC)
- Quantum Support Vector Machines (QSVM)
- Quantum Neural Networks (QNNs)
- Quantum k-means clustering, QPCA

Hybrid Models (Classical + Quantum mix)

- Neural networks with quantum layers
- Quantum feature maps + classical optimizers

Classical ML for Quantum Tasks

- Predicting quantum circuit outcomes
- Optimizing quantum control parameters
- Noise mitigation using ML models (AlphaQubit)

Clever QML

- Quantum Hadamard Edge Detection
- Quantum Kernels, ...etc



Why Quantum Machine Learning?

Classical ML Challenge

- X** Large feature spaces
- X** High-dimensional data
- X** Slow kernel evaluations
- X** Non-convex optimization

Quantum Advantage Potential

- ✓** Superposition: explore all at once
- ✓** Hilbert space embedding
- ✓** Quantum kernel methods (Faster, Secure)
- ✓** Quantum annealing, QAOA, VQE

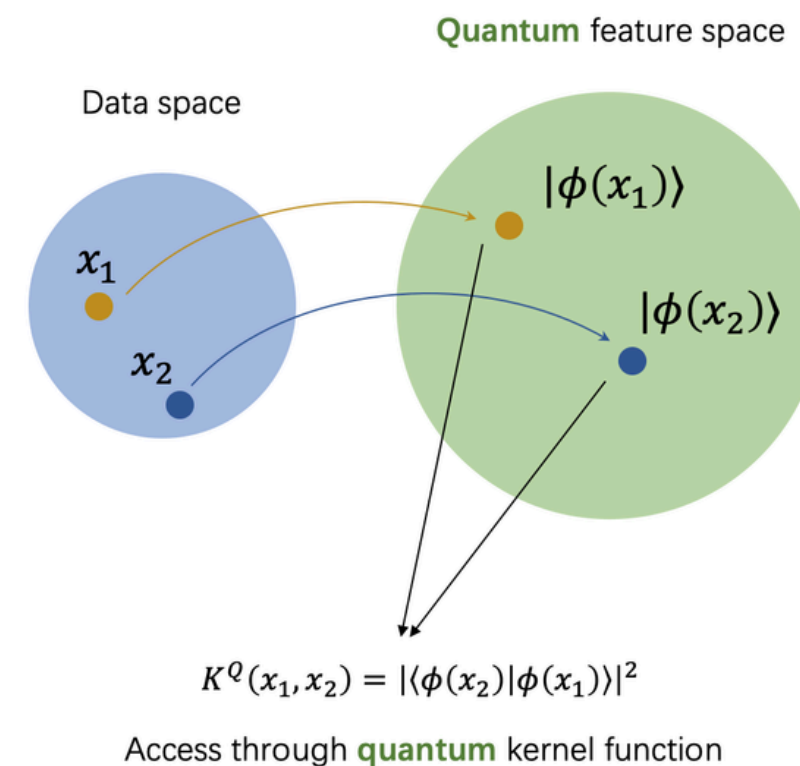
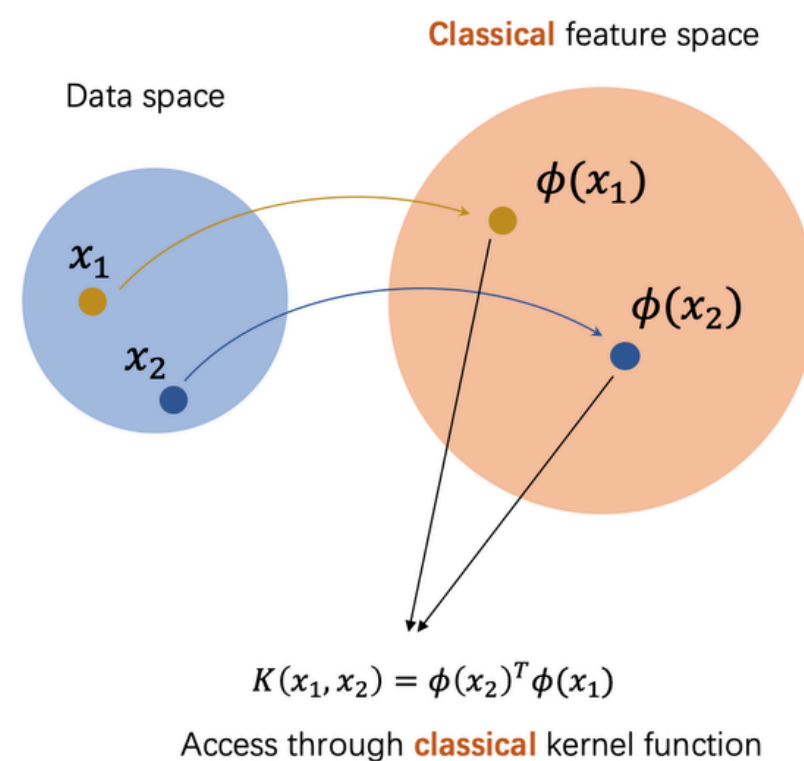

Sample Complexity Classical vs Quantum ML

Classical ML

The number of training examples required for a model to generalize effectively

Ex: Number of labeled images needed to train an image classifier

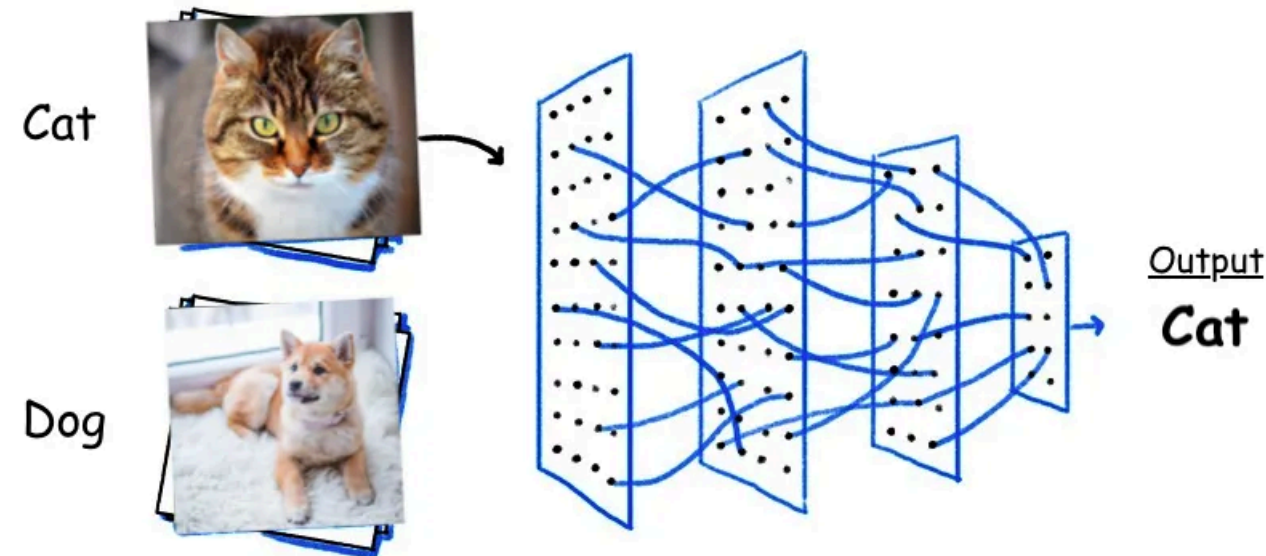

Quantum ML

Varies meanings depending on the context

- **Quantum state tomography:** refers to the number of measurements required to accurately reconstruct the quantum state of a system.
- **Evaluation of the generalization ability of quantum neural networks:** refers to the number of input-output pairs needed to train the network to approximate a target function, similar to classical ML.
- **Quantum system learning:** refers to the number of queries to interact with the target quantum system, such as the number of times a system must be probed to learn its Hamiltonian dynamics.

QML Pipeline

From Classical Data to Quantum Data

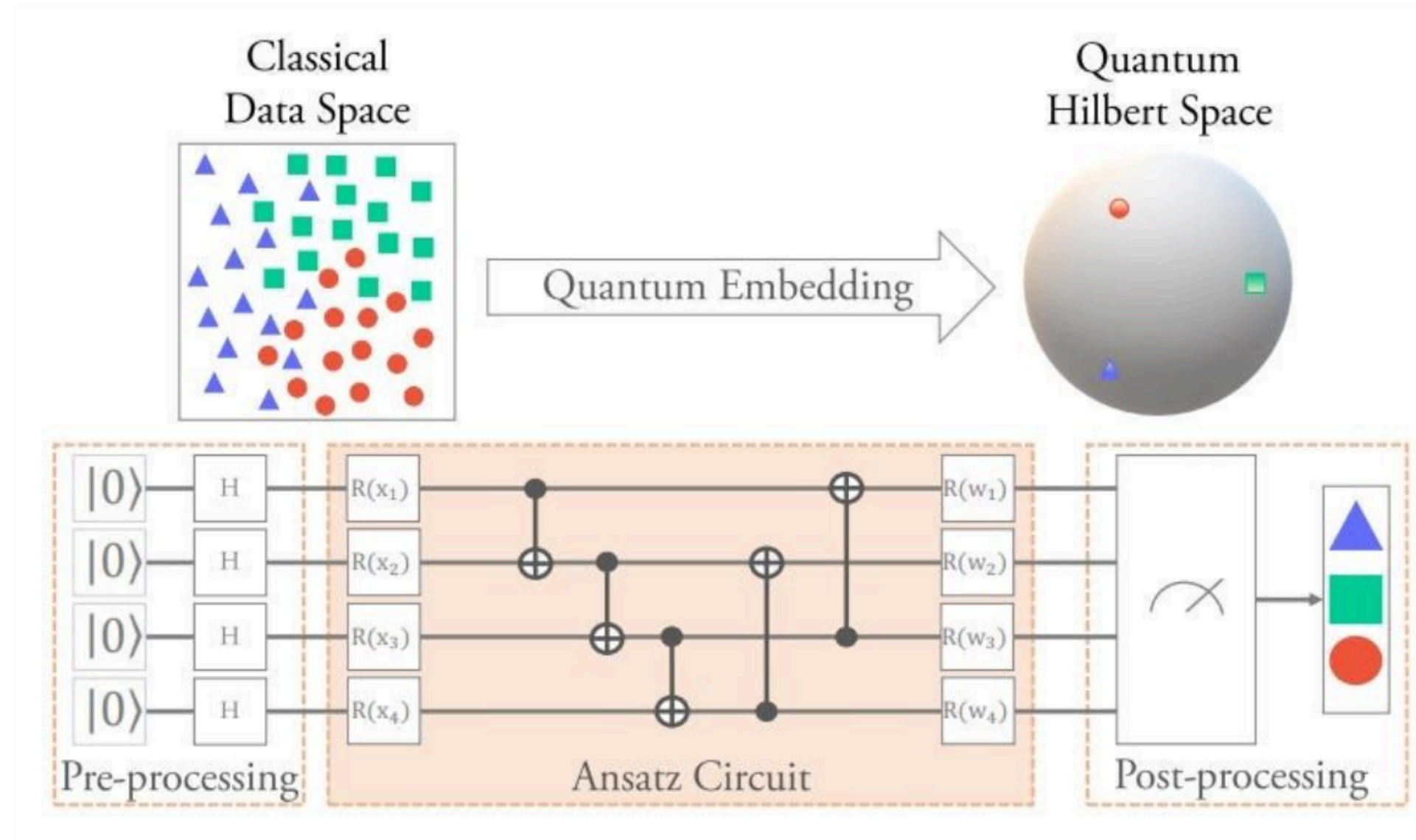

- Nguyen, N., & Chen, K. C. (2022). Quantum embedding search for quantum machine learning. *IEEE Access*, 10, 41444-41456.



Quantum Applications

Fast search

Grover's algorithm offers a quadratic speed-up, enabling search in an unstructured database with a time complexity of $O(\sqrt{N})$ compared to the classical $O(N)$



Memory and power saving

1024x1024 pixels



~1M bits

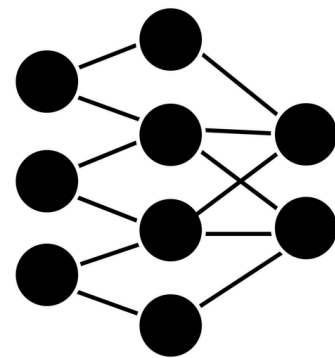

2^n features, $n=20$ qubits

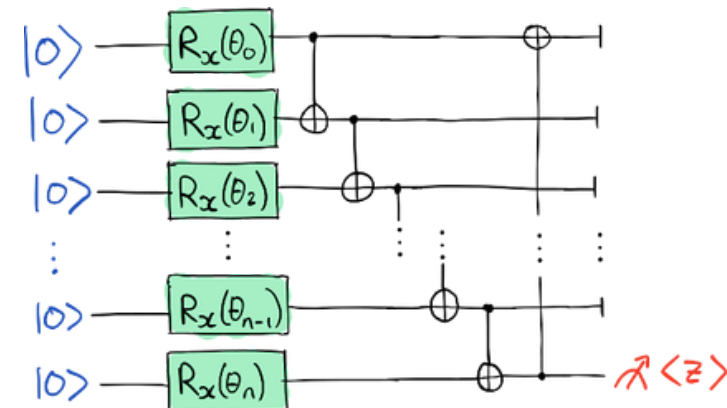

Shor's Algorithm

Factor large composite numbers into their **Prime Factors** in polynomial time

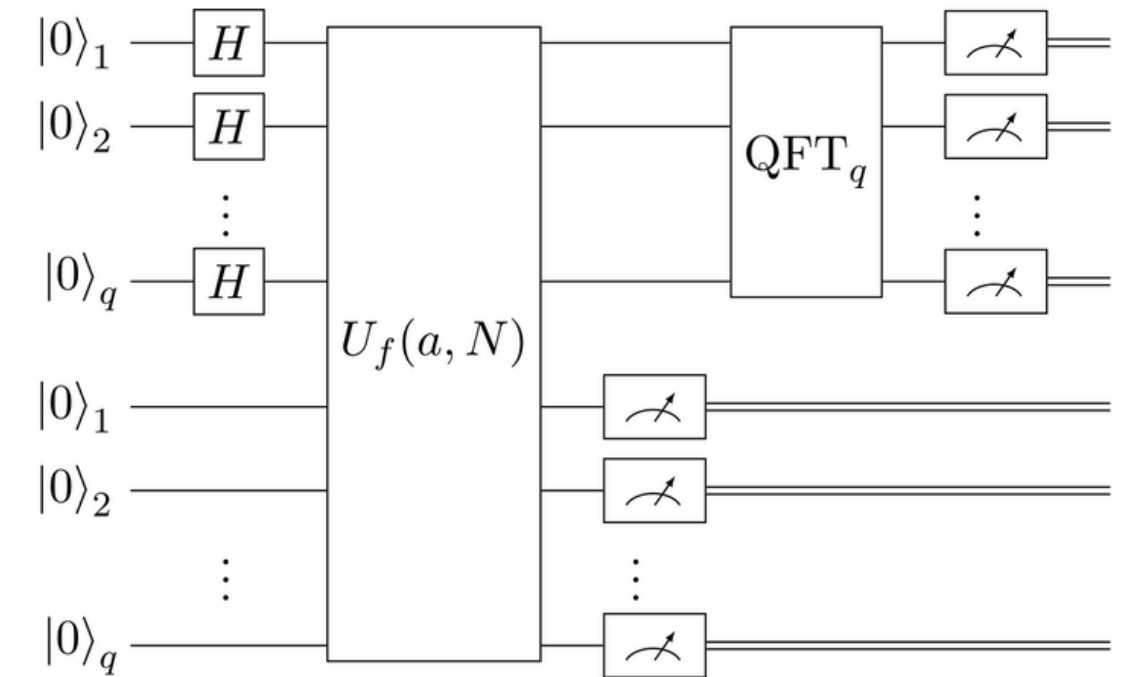



GPT on a Quantum Computer

GPT-3's 175 Billion parameters as amplitudes can be encoded on 38 qubits

$$n = \lceil \log_2(175 \times 10^9) \rceil = 38 \text{ qubits.}$$

16-bit (FP16/-like): $175\text{B} \times 16 = 2.8 \times 10^{12} \text{ bits} \approx 350 \text{ GB}$

Big Claim!!!!

Account for precision, qRAM, state-prep, and error correction pushes requirements vastly beyond 38 qubits



Quantum Data Encoding

Basic Encoding

represent each
classical bit as a qubit
state $|0\rangle, |1\rangle$

Angular Encoding

encode features into
rotation angles,
e.g: $x \rightarrow R_y(x)$

Amplitude Encoding

encode an entire normalized vector
into amplitudes of a quantum state
(compact but costly to prepare)

Quantum Kernel Feature Maps

Quantum computers naturally map data into Hilbert space. The map that performs the embedding is called “Quantum Feature Map”

In this example, data is embedded into Hilbert spaces, and can be viewed as a geometrical sphere, which differentiates two classes of data into 2 Hilbert spaces, and ultimately stores embedded data into a 2-qubit system contains 4 basis states

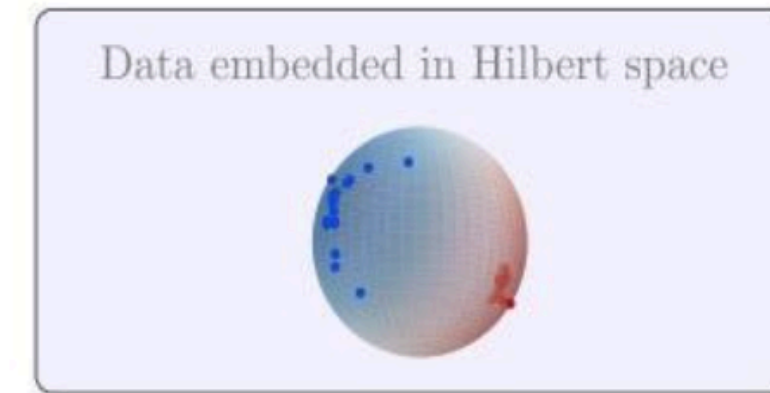
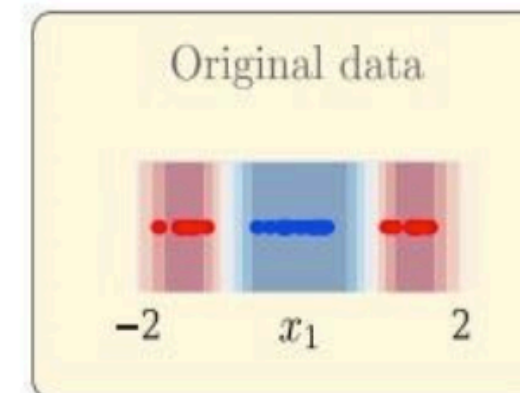

$x \rightarrow |\phi(x)\rangle \rightarrow \text{map transforms}$

$U_\phi(x)$

Quantum Models Representation

Instead of using neurons, weights, layers in Classical ML



We Use **Parameterized Quantum Circuits (PQCs)**, where unitary gates with tunable parameters play the role of weights (θ)

- Quantum circuits naturally represent high-dimensional Hilbert space functions.
- Some functions that require exponentially large classical networks can be compactly expressed with shallow quantum circuits

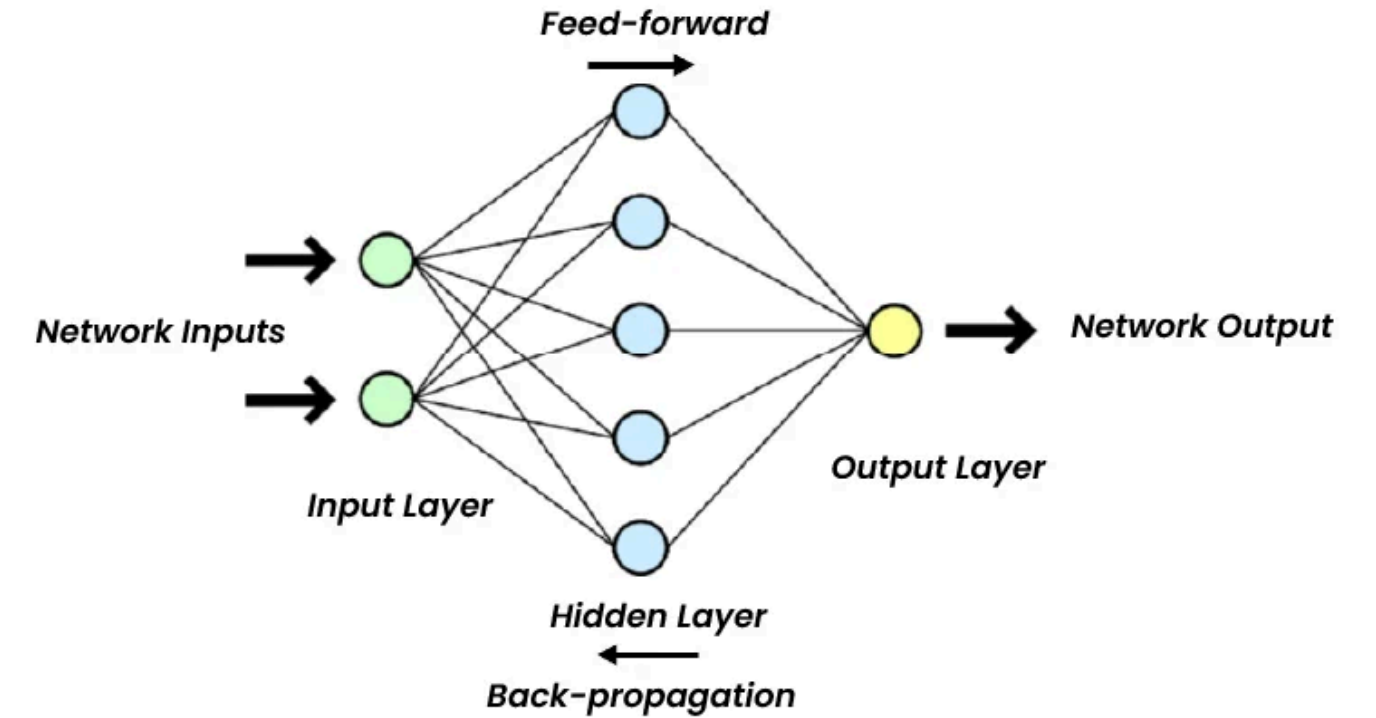

Classical CNN

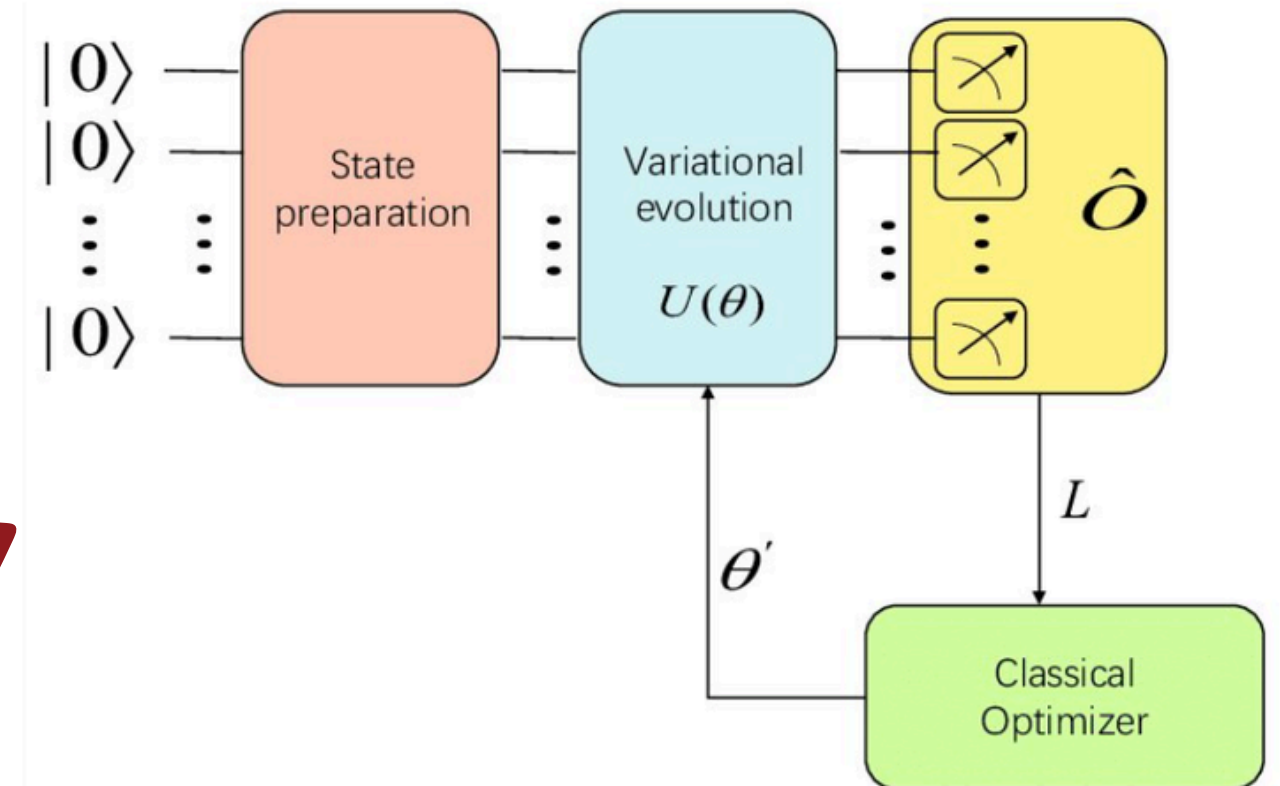

Quantum NN

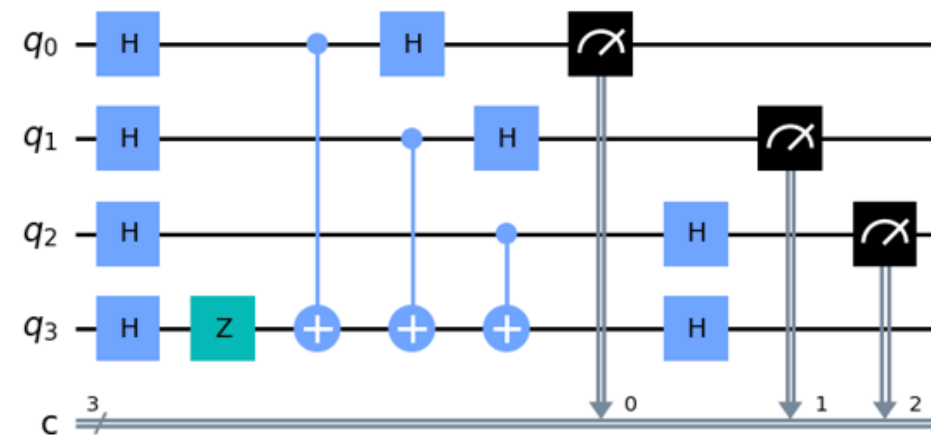

Quantum Circuit



Quantum Learning Process

Forward pass:

- Encode classical input into quantum state.
- Apply parameterized circuit $U(\theta)$.
- Measure expectation values \rightarrow outputs a probability distribution.

Training loop:

- Define a loss function: e.g., expectation value differences from labels.
- Classical optimizer updates circuit parameters θ .
- Iterate until convergence.

Gradients:

- Measured using the parameter-shift rule:

$$\frac{\partial f}{\partial \theta} = \frac{f(\theta + \pi/2) - f(\theta - \pi/2)}{2}$$

- This avoids backprop but requires more circuit evaluations.



Training in QML

Variational Quantum Circuits (VQCs)

- **Most popular NISQ method - Trainable Unitaries, loss defined via measurements, optimized by classical gradient descent.**
- **Challenges: barren plateaus (vanishing gradients)**

Quantum Kernels

- **Quantum computers define feature maps in Hilbert space.**
- **Use inner products between quantum states (kernel trick). Example: Quantum SVM.**

Quantum Generative Models

- **Quantum Boltzmann Machines.**
- **Quantum GANs: quantum generator with classical discriminator (or vice versa)**

Fully Quantum Training (future)

- **Algorithms like Quantum Backpropagation exist in theory, but are limited by the current noisy devices.**

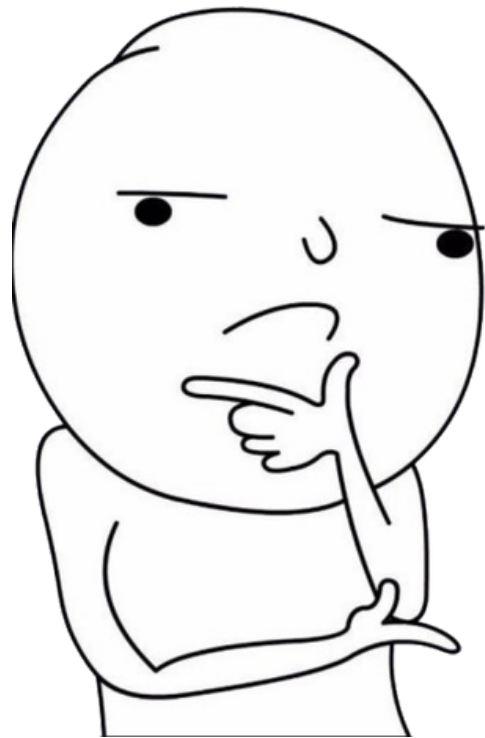

Are We Doing QML Right?!!

**Should we invest in QML if classical
ML is working well?**

QML Use Cases

Large Language Models (LLMs)

Quantum Combinatorial Reasoning for LLMs:

- QCR-LLM, a hybrid framework that integrates LLMs with a quantum reasoning engine. They break reasoning into small fragments and treat composition as structured selection.
- QCR-LLM reformulates reasoning aggregation as a higher-order unconstrained binary optimization (HUBO) problem

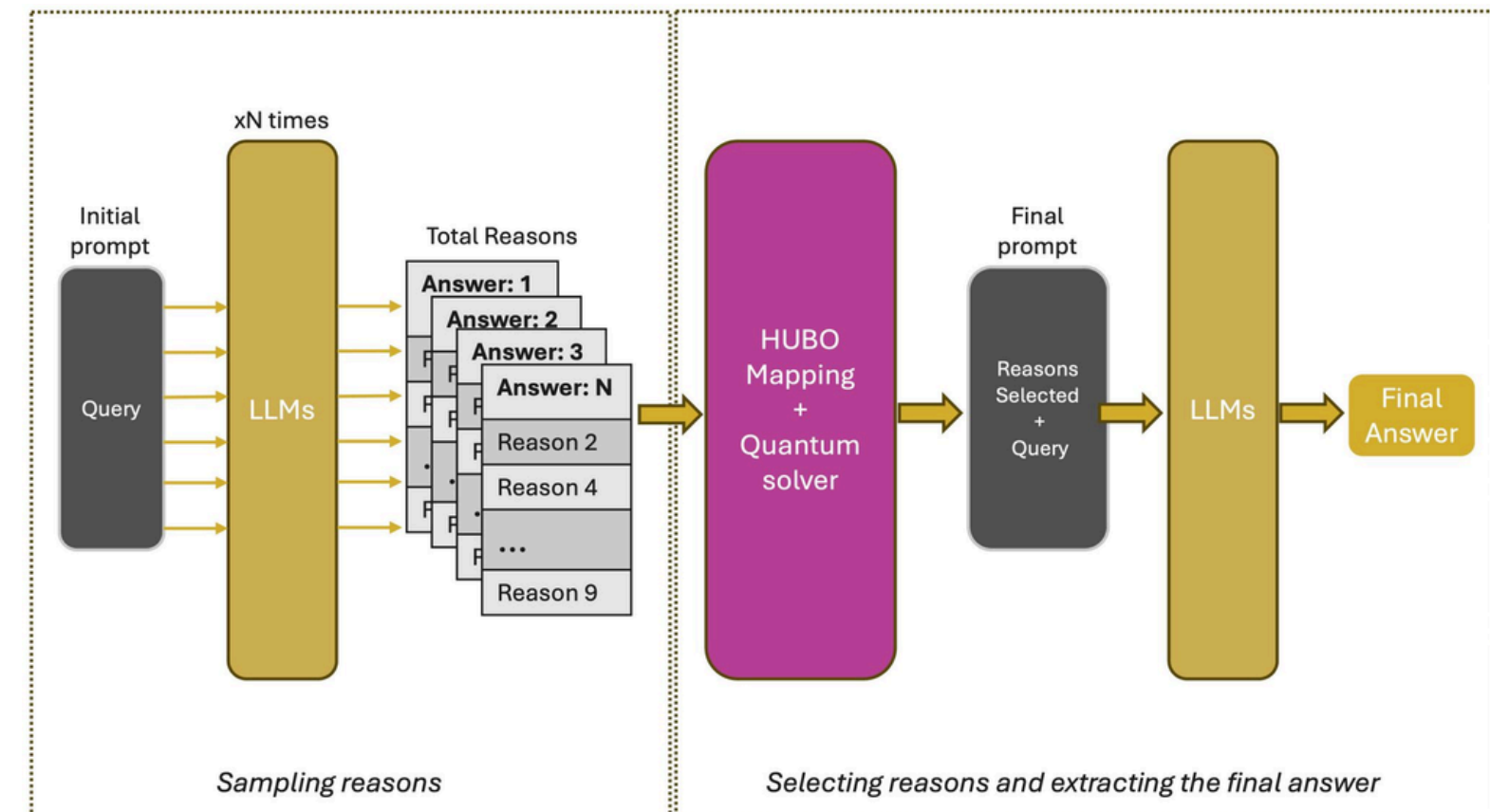

QML Use Cases

Drug Discovery & Molecular Simulation

Quantum-enhanced generative models

- QML models used to generate and classify molecular structures
- Variational quantum circuits predict molecule properties (toxicity, solubility)
- Accelerates drug design

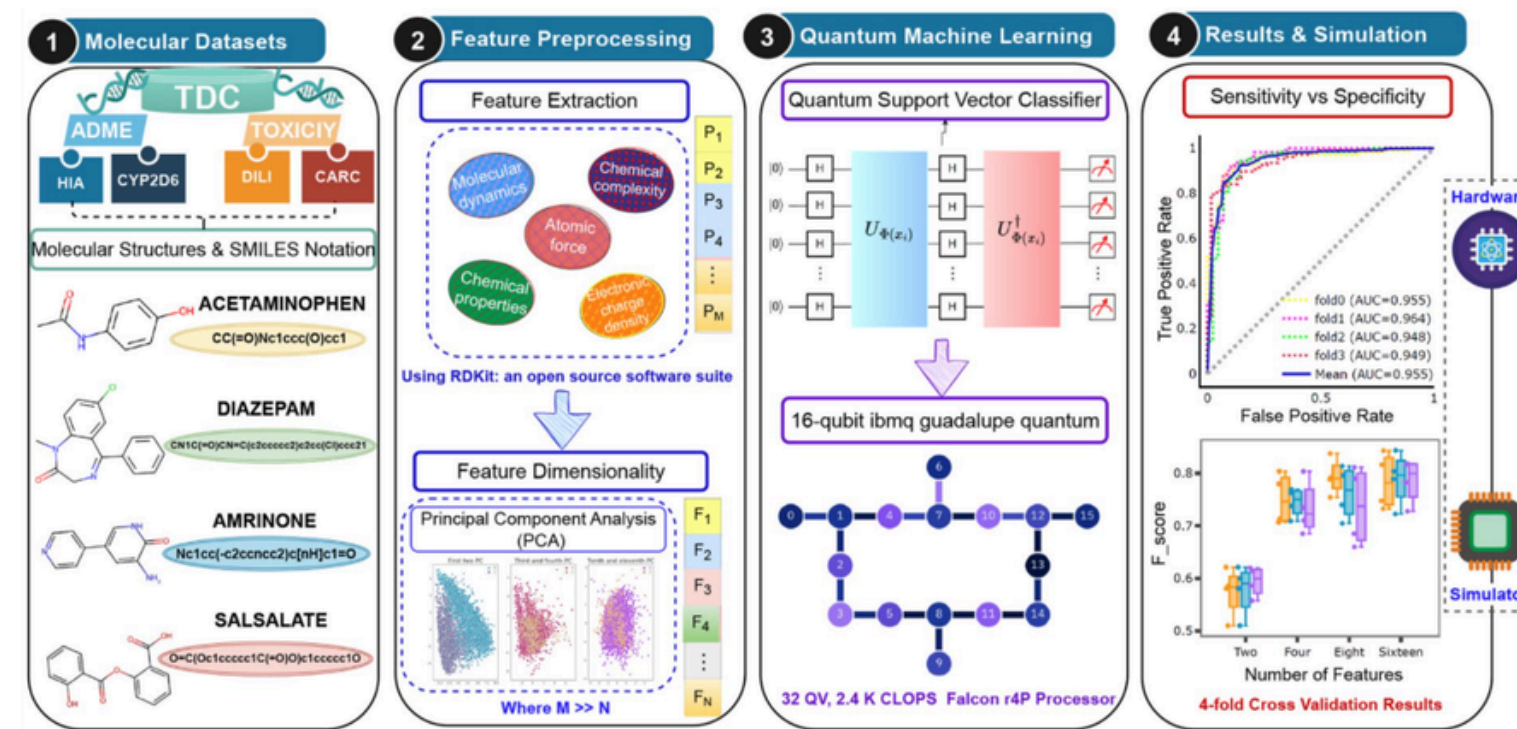

- Quantum Machine Learning Predicting ADME-Tox Properties in Drug Discovery
Amandeep Singh Bhatia, Mandeep Kaur Saggi, and Sabre Kais Journal of Chemical Information and Modeling 2023, 63, 21, 6476-6486

QML Use Cases

Healthcare & Medical Imaging

Quantum Hadamard Edge Detection

- QML used to enhance medical image processing (e.g., MRI, CT scans)
- Quantum edge detection using Hadamard transforms improves contrast and boundary accuracy

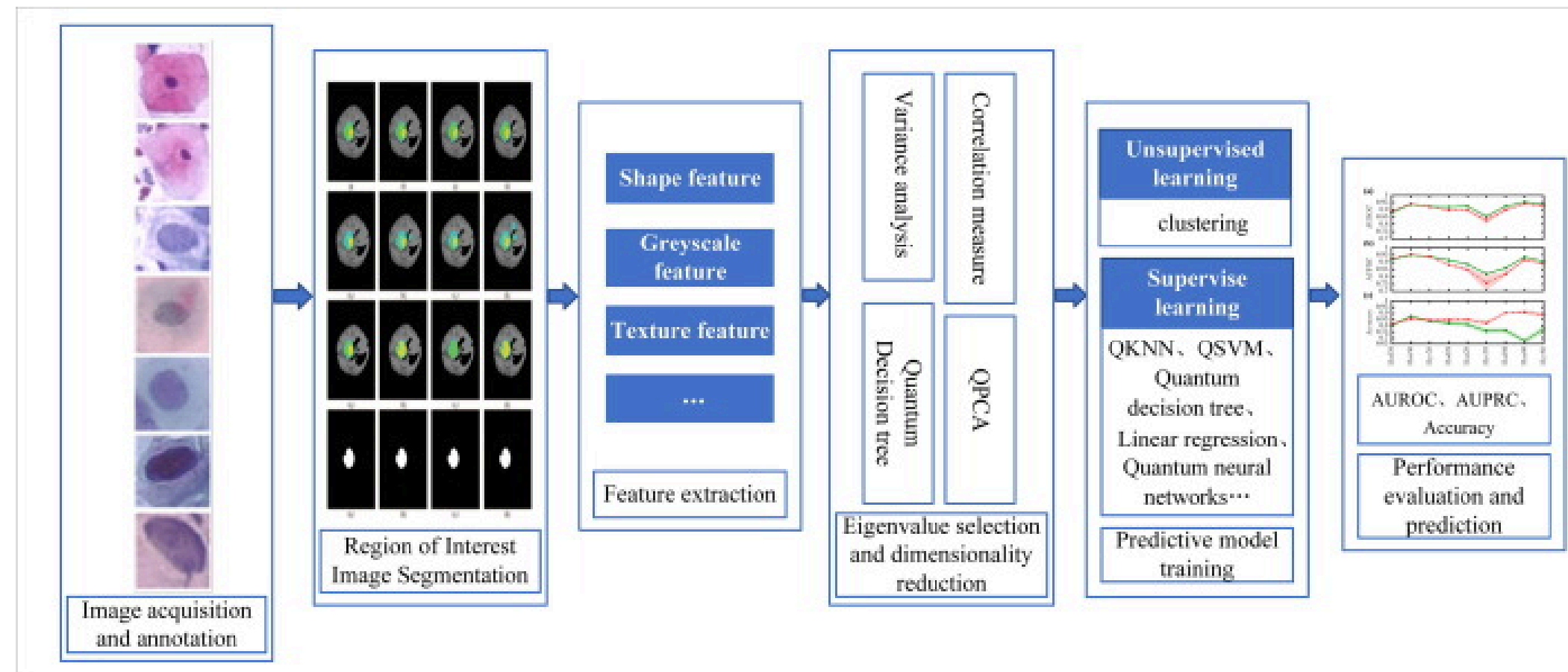

Can quantum ideas make smaller AI models smarter?

Large Language Models (LLMs)

Deploying smaller, offline models is increasingly vital for privacy and edge applications

Training compact models to mimic larger ones

Quantum Relational Knowledge Distillation, a new approach that maps data into quantum states and leverages quantum relationships like entanglement-inspired structures to improve the knowledge distillation process.

Incorporating this quantum information technique into the knowledge distillation process enhances the smaller 'student models', performance on some widely used benchmark text datasets.

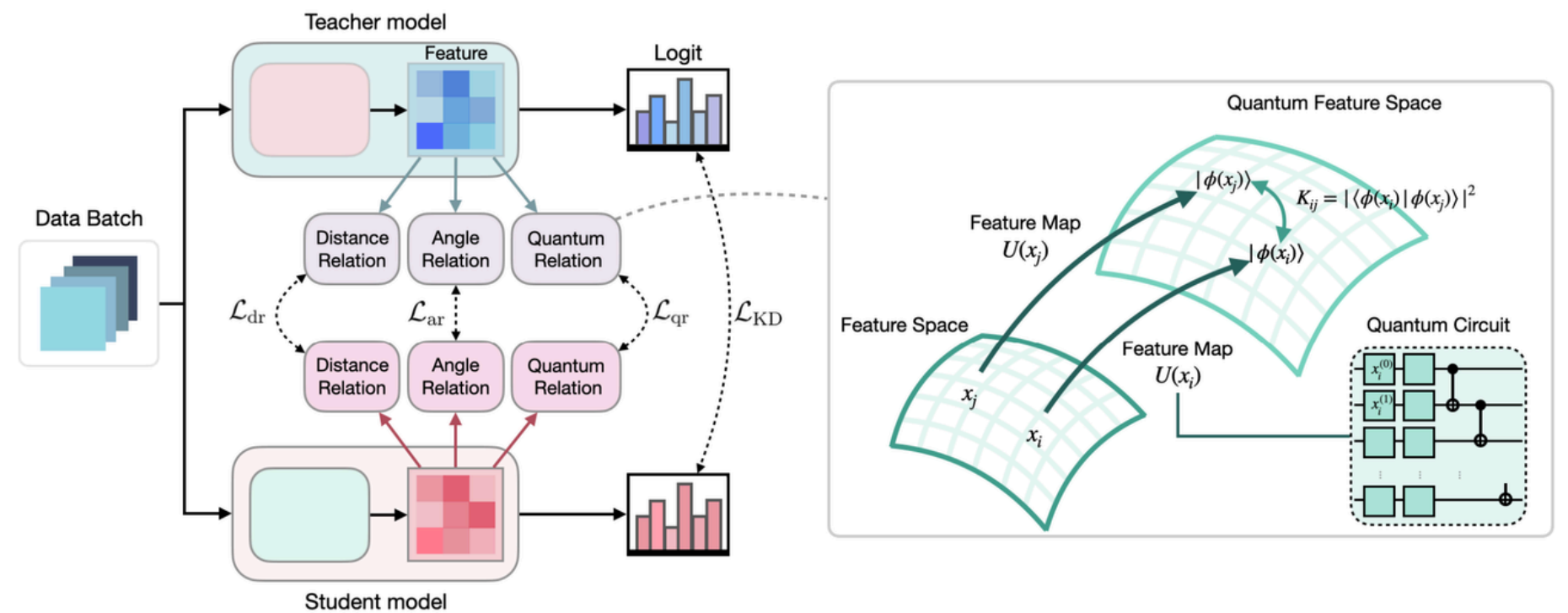

Quantum Relational Knowledge Distillation, <https://doi.org/10.48550/arXiv.2508.13054>



QUANTINUUM



KØBENHAVNS
UNIVERSITET

Quantum NLP

Using CCG (Combinatory Categorical Grammar) Instead of Vector Embedding Encoding Sentences into String Diagrams and Quantum Circuits

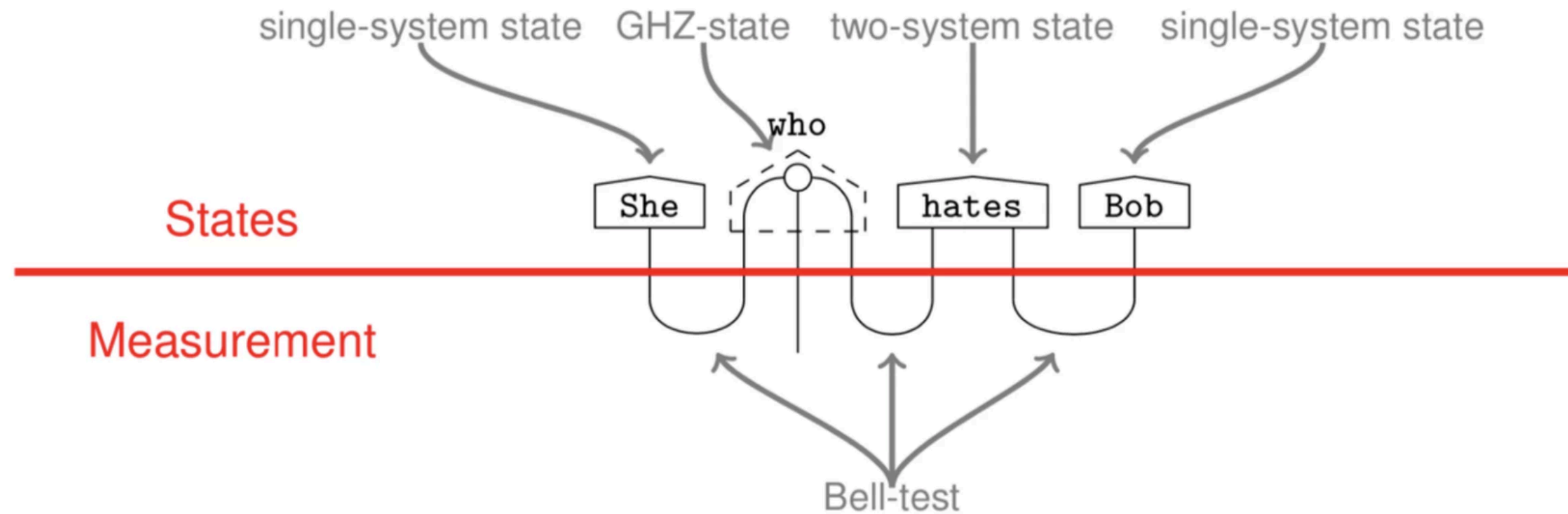

Quantum Error Correction Fault - Tolerant Era

Threshold Theorem

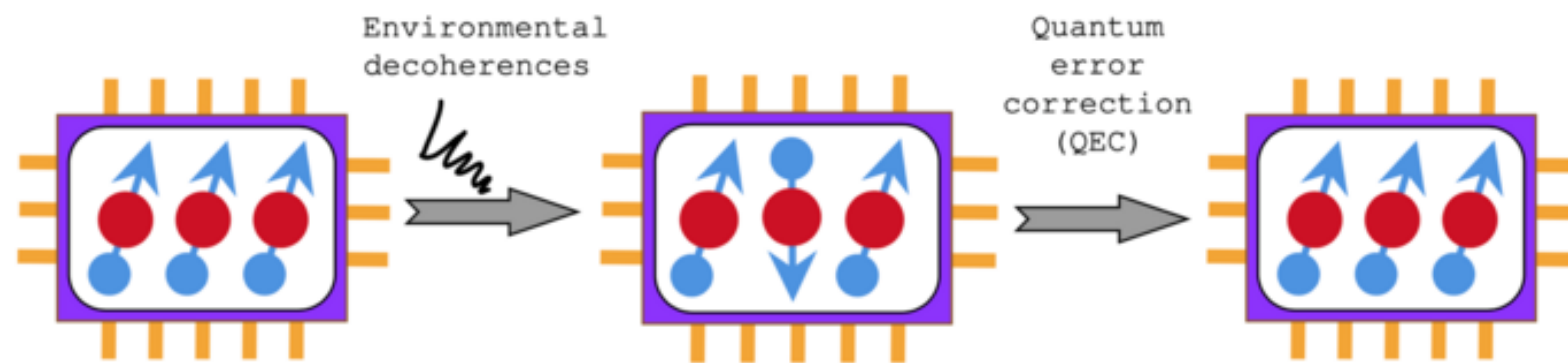

AlphaQubit AI-based Decoder

By Google DeepMind and
Quantum AI teams

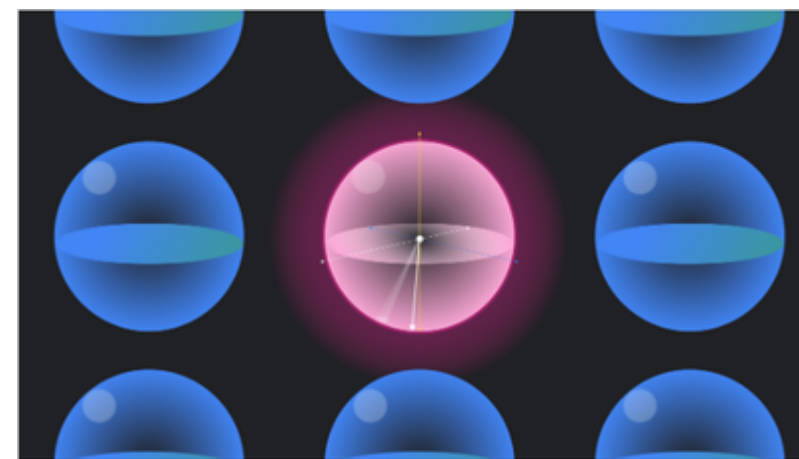

AlphaQubit tackles one of quantum computing's biggest challenges
AlphaQubit is an AI-based decoder that identifies quantum computing errors with state-of-the-art accuracy.
Google / Nov 20, 2024

1 Logical Qubit

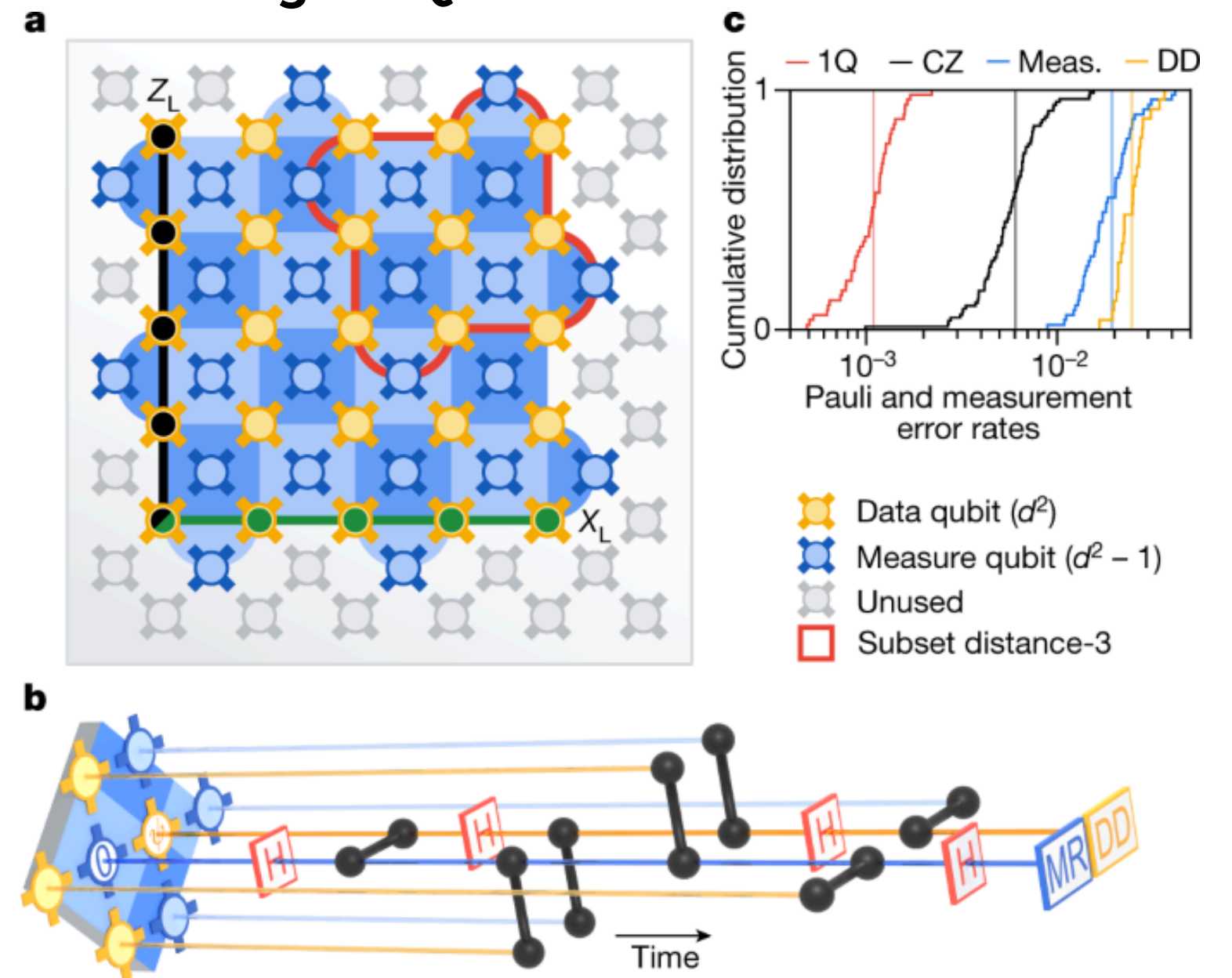



QML Limitations

Scalability / Hardware: Barren Plateaus

McClellan et al. (2018) showed that as quantum circuits get deeper, the gradients used for training vanish exponentially (the “barren plateau” problem). This means optimization becomes nearly impossible at scale.

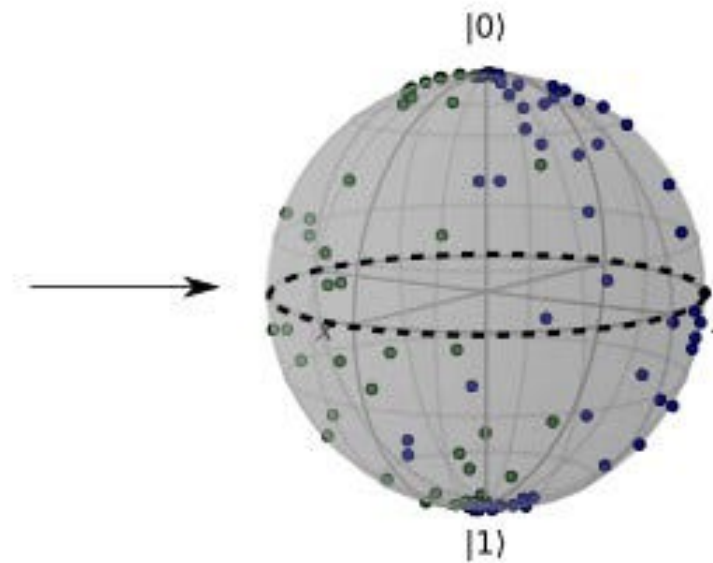
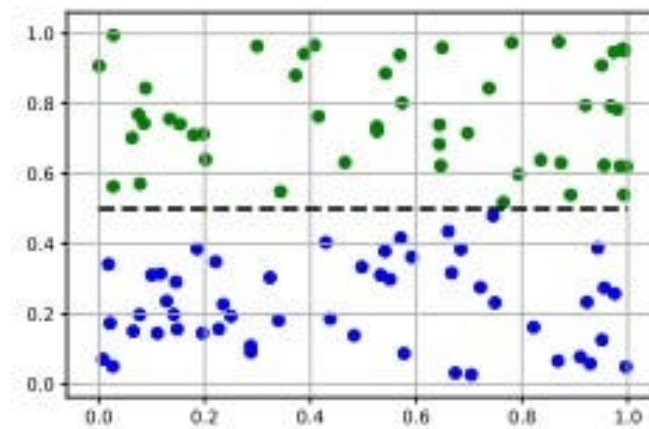
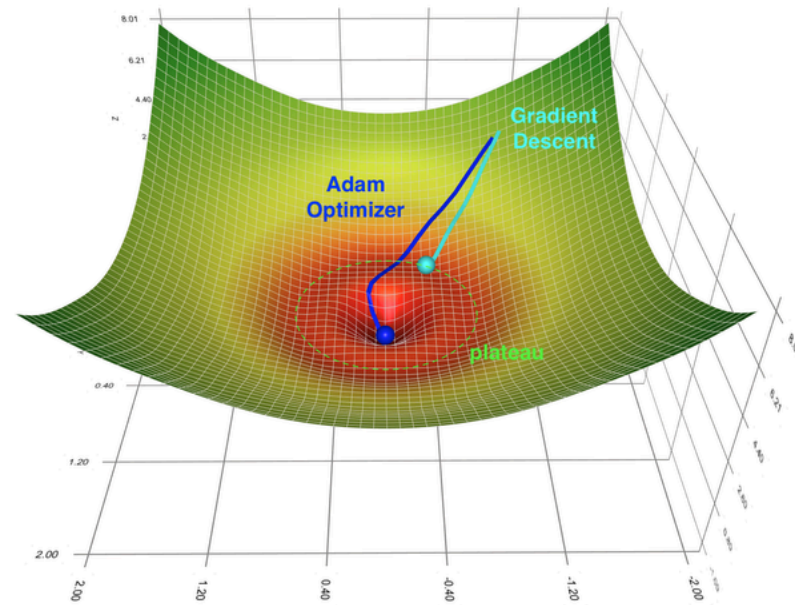

Data Problems

No-Cloning Theorem: Arbitrary quantum states cannot be perfectly copied, preventing traditional backup or replication methods for quantum data

Measurement Limitation: Measuring a quantum state causes it to collapse, destroying the superposition and forcing a non-deterministic result, which limits data retrieval

Decoherence and Noise: Qubits are extremely sensitive to environmental interference (temperature, vibration), leading to rapid decoherence where quantum information is lost.

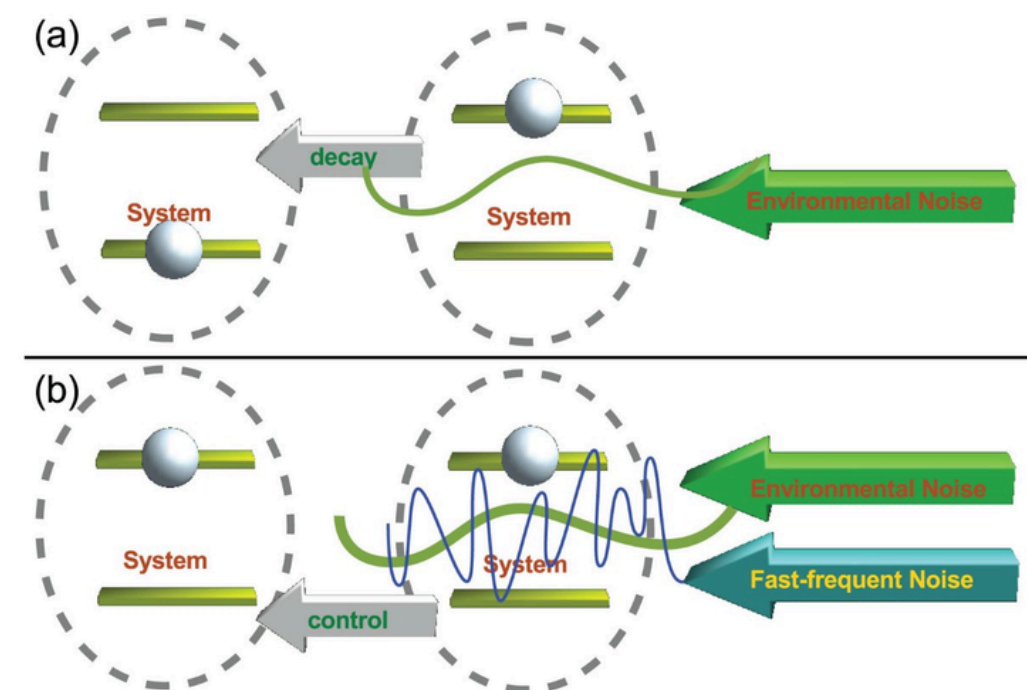



QML Limitations

Dequantization: Classical Catch-Up

Tang (2019) proved that some problems thought to show exponential QML advantage (like quantum recommendation systems) can be solved by efficient classical algorithms. This weakens claims that quantum models inherently outperform classical ones on such tasks.

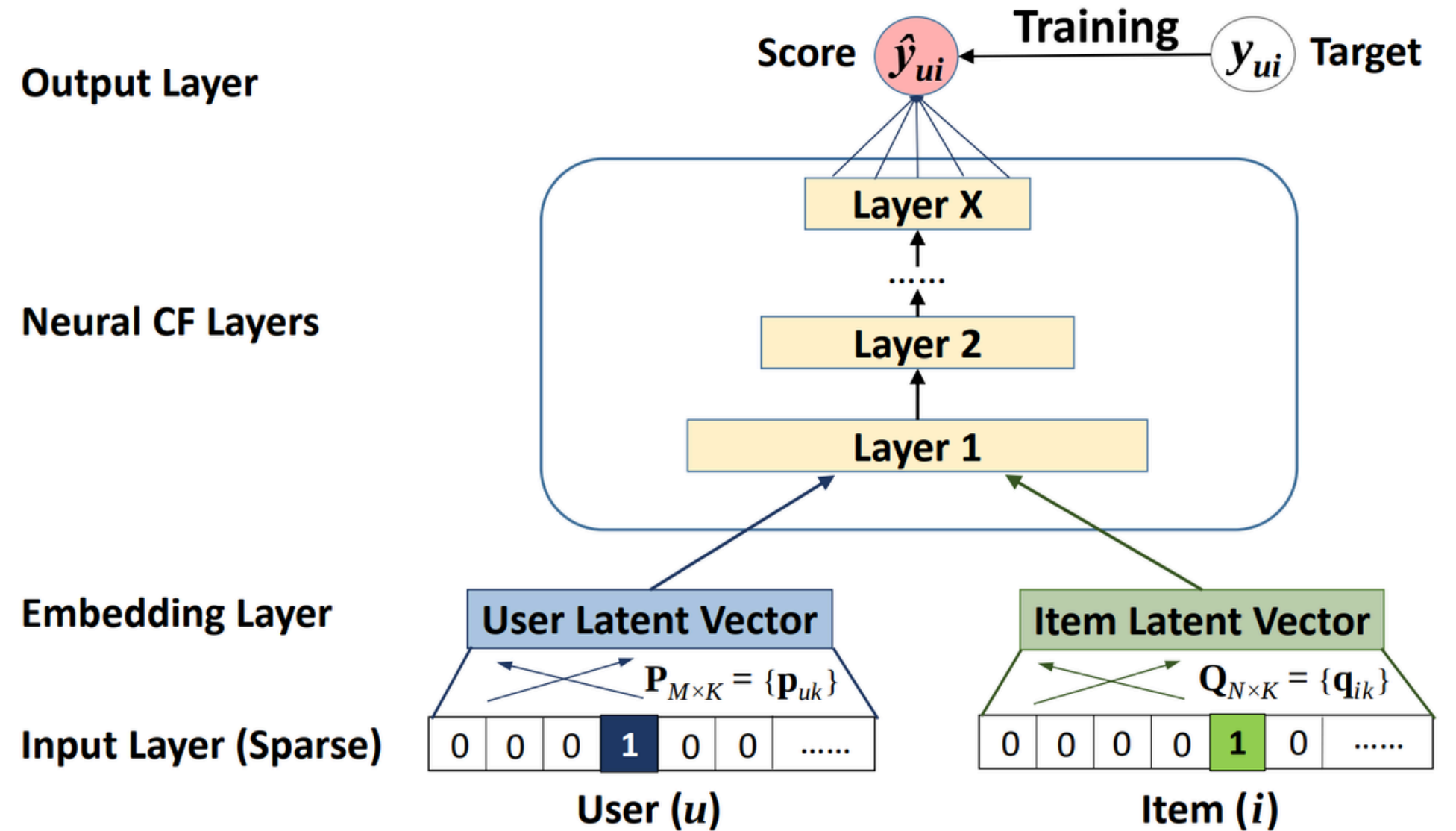

QML Limitations

Data Bottlenecks: The QRAM Problem

Many QML algorithms assume fast quantum access to massive classical datasets (via QRAM). Hann (2021) highlighted that building large, fault-tolerant QRAM is technically very difficult, making such assumptions unrealistic in the near term.

Hype Danger – Exaggerated Speedups

Aaronson (2015) cautioned that many claimed QML speedups rely on idealized conditions (perfect data loading, error-free devices, oracles). Without these, the promised exponential gains often disappear, meaning we should “read the fine print” before accepting big claims.

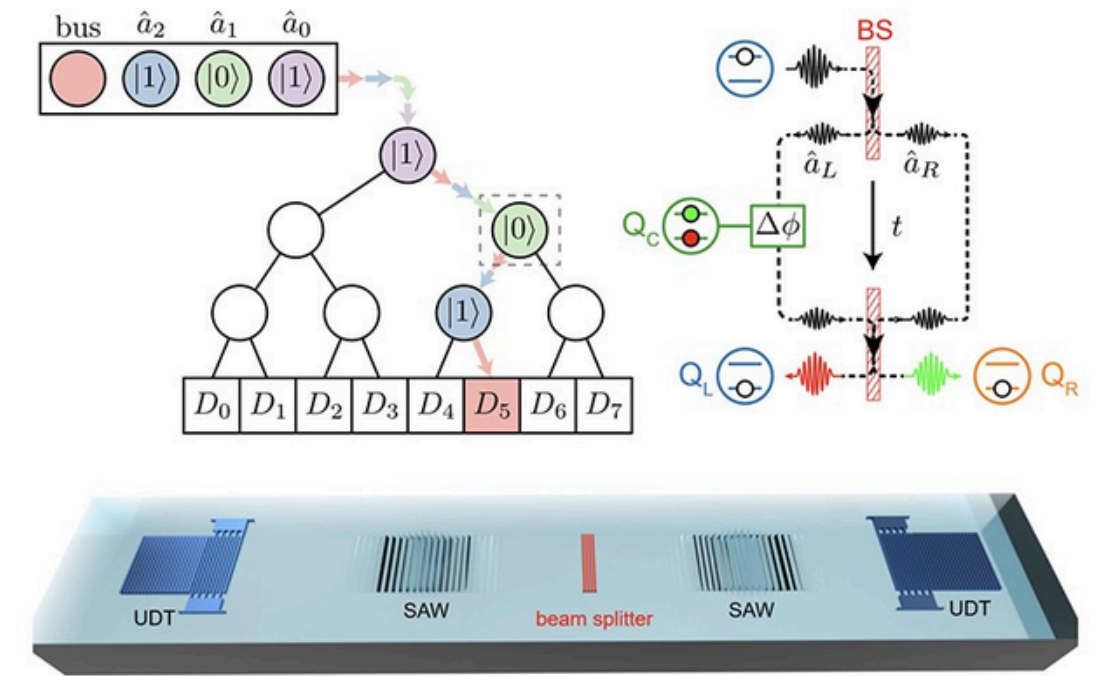

Schematic of the bucket-brigade QRAM architecture (Photo by Physical Review Letters. DOI: 10.1103/PhysRevLett.134.210601)

Achieving Practical Quantum Advantage

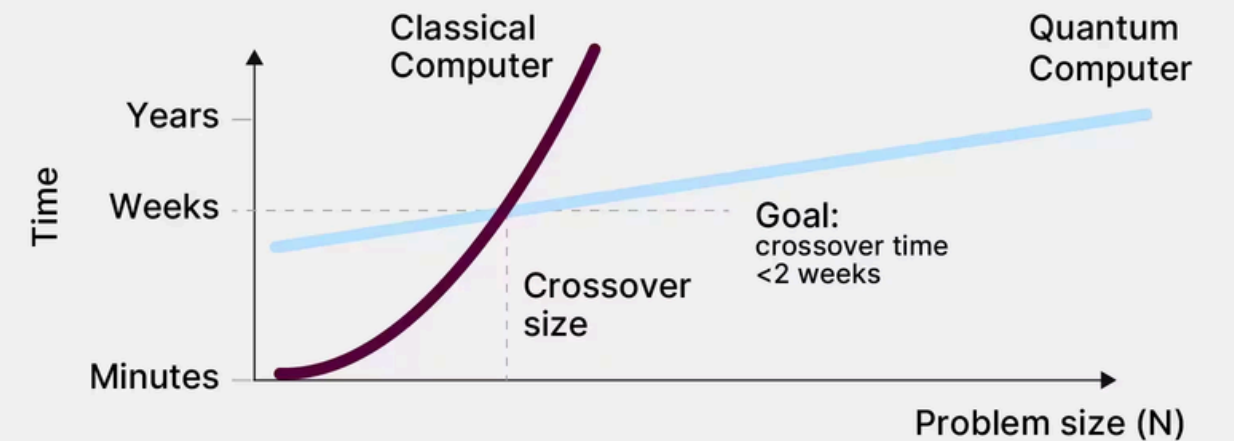

Source: Microsoft



Quantum Software Frameworks for QML

PennyLane (by Xanadu)



PENNYLANE

A hybrid quantum-classical machine learning framework that enables automatic differentiation through quantum circuits.

- **Classical ML libraries:** PyTorch, TensorFlow, JAX
- **Quantum backends:** Strawberry Fields, Qiskit, Cirq, Amazon Braket, IonQ, Rigetti, etc.
- **Use Cases:** Variational quantum classifiers, QGANs, quantum kernels, etc
- **Key Features:**
 - Differentiable quantum nodes (@qml.qnode)
 - Training quantum circuits like neural networks



Quantum Software Frameworks for QML

By Google Quantum AI



Google AI
Quantum



OpenFermion

An open-source library for translating problems in chemistry and materials science into quantum circuits that can be executed on existing platforms.



TensorFlow Quantum

A quantum machine learning library for rapid prototyping of hybrid quantum-classical ML models from within TensorFlow.



qsim

A fast quantum circuit simulator that integrates with Cirq and makes it easy to power quantum simulations with high-performance classical hardware



Quantum Software Frameworks for QML

By IBM

qiskit-community/qiskit- machine-learning

Quantum Machine Learning



81

Contributors

518

Used by

885

Stars

400

Forks





Quantum Software Frameworks for QML

By Nvidia



NVIDIA®



CuQuantum

NVIDIA cuQuantum is an SDK of optimized libraries and tools that accelerate quantum computing emulations at both the circuit and device level by orders of magnitude.



Some Resources to Learn QML

arXiv:2502.01146v1 [quant-ph] 3 Feb 2025

Quantum Machine Learning A Hands-on Tutorial for Machine Learning Practitioners and Researchers

Yuxuan Du^{1,*},† Xinbiao Wang^{1,*} Naixu Guo^{2,*}
Zhan Yu^{2,*} Yang Qian^{1,*} Kaining Zhang^{1,*}
Min-Hsiu Hsieh^{3,1} Patrick Rebentrost^{2,1} Dacheng Tao^{1,†}

¹ College of Computing and Data Science, Nanyang Technological University, 639798, Singapore
² Centre for Quantum Technologies, National University of Singapore, 117543, Singapore

Quantum Machine Learning: Where Are We and What Is Next?

Yousra Farhani
jy_farhani@esi.dz
Ecole Nationale Supérieure d'Informatique (ESI Alger)
Oued Smar, Algiers, Algeria

ABSTRACT

Quantum Machine Learning (QML) is evolving rapidly as improvements in quantum hardware, algorithmic theory, and hybrid quantum-classical software frameworks continue to unfold. Despite the high volume of published research, a set of unresolved challenges has motivated an increasingly critical examination of whether current approaches in QML are genuinely exploit the capabilities of quantum information processing. In this paper, a comprehensive narrative is developed that integrates the latest advances in quantum hardware, foundational principles of QML, methodological developments, present limitations, and emerging directions that will shape the near future of quantum learning. Drawing upon recent experimental milestones, theoretical studies, and applications across healthcare, environmental analytics, and molecular science, this manuscript clarifies where QML stands today and what is required for meaningful progress in the transition toward the fault-tolerant quantum era.

CCS CONCEPTS

• General and reference → Surveys and overviews; • Mathematics of computing → Quantum computation; • Computing methodologies → Machine learning; • Applied computing;

surrounding quantum computing and the belief that quantum information processing may unlock new computational paradigms for high-dimensional learning tasks. Biamonte et al. provide an early foundational definition of QML that formally links quantum computation with the core principles of machine learning, illustrating how superposition, entanglement, and unitary evolution might enhance pattern recognition and optimization processes [Biamonte et al. 2017]. The field continues to evolve as researchers critically examine whether these anticipated advantages can be realized in practice.

Parallel to the algorithmic advancements, quantum hardware has progressed significantly. Google's Willow processor demonstrated below-threshold error rates for superconducting qubits, establishing an experimental milestone toward scalable fault-tolerant computing, while IBM's Heron processor introduced improved tunable coupler designs and considerably reduced gate errors [AI 2024; Quantum 2024]. These hardware successes suggest that deeper and more expressive variational quantum circuits may soon be feasible. In addition, D-Wave's Advantage2 system reached a remarkable demonstration of beyond-classical performance on a spin-glass materials simulation benchmark, surpassing the Frontier supercomputer in a key study by King et al. [King et al. 2025]. Together, these developments invite a reassessment of how QML models may

Open Graph image

Chapter 1 Introduction of QML

Introduction The advancement of computational power has always been a driving force behind every major industrial revolution. The invention of the modern computer, followe...

Quantum Machine Learning Tutorial



Contents lists available at ScienceDirect

Neurocomputing

journal homepage: www.elsevier.com/locate/neucom

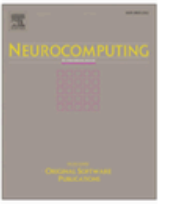

Quantum Machine Learning: A tutorial

José D. Martín-Guerrero^{a,*}, Lucas Lamata^b

^a Departament d'Enginyeria Electrònica, ETSE-UV, Universitat de València (UV), Spain
^b Departamento de Física Atómica, Molecular y Nuclear, Universidad de Sevilla, 41080 Sevilla, Spain

ARTICLE INFO

Article history:
Received 5 December 2020
Accepted 19 February 2021
Available online 22 July 2021
Communicated by Zidong Wang

Keywords:

Quantum computing
Computational speed-up
Quantum-inspired learning algorithms
Quantum clustering
Quantum reinforcement learning
Quantum autoencoders

ABSTRACT

This tutorial provides an overview of Quantum Machine Learning (QML), a relatively novel discipline that brings together concepts from Machine Learning (ML), Quantum Computing (QC) and Quantum Information (QI). The great development experienced by QC, partly due to the involvement of giant technological companies as well as the popularity and success of ML have been responsible of making QML one of the main streams for researchers working on fuzzy borders between Physics, Mathematics and Computer Science. A possible, although arguably coarse, classification of QML methods may be based on those approaches that make use of ML in a quantum experimentation environment and those others that take advantage of QC and QI to find out alternative and enhanced solutions to problems driven by data, often-times offering a considerable speedup and improved performances as a result of tackling problems from a complete different standpoint. Several examples will be provided to illustrate both classes of methods.

© 2021 The Authors. Published by Elsevier B.V. This is an open access article under the CC BY-NC-ND license (<http://creativecommons.org/licenses/by-nc-nd/4.0/>).



KØBENHAVNS
UNIVERSITET

Thank You!